

REVISION HISTORY			
REV	DATE	BY	DESCRIPTION
B	03FEB2014	ACH/ASM	PRN: P2014-0102

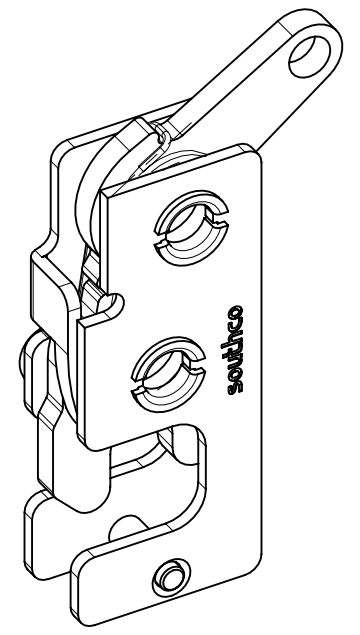
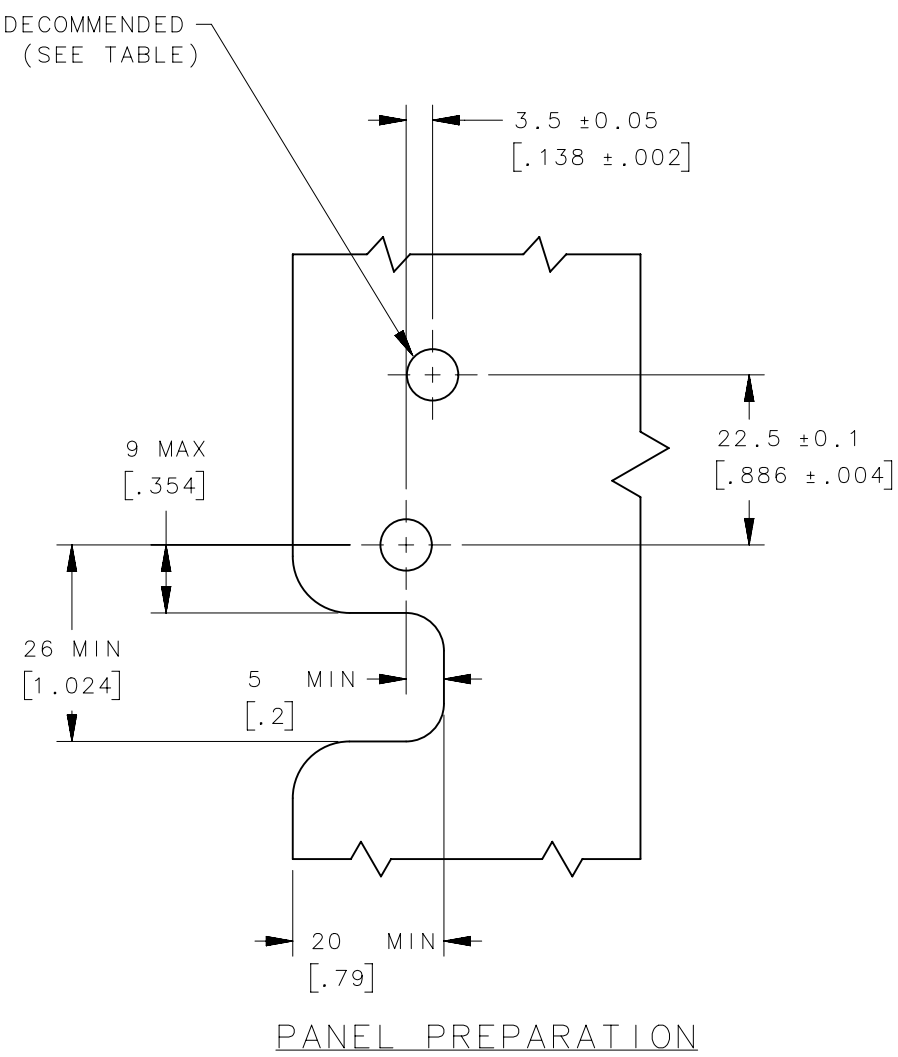
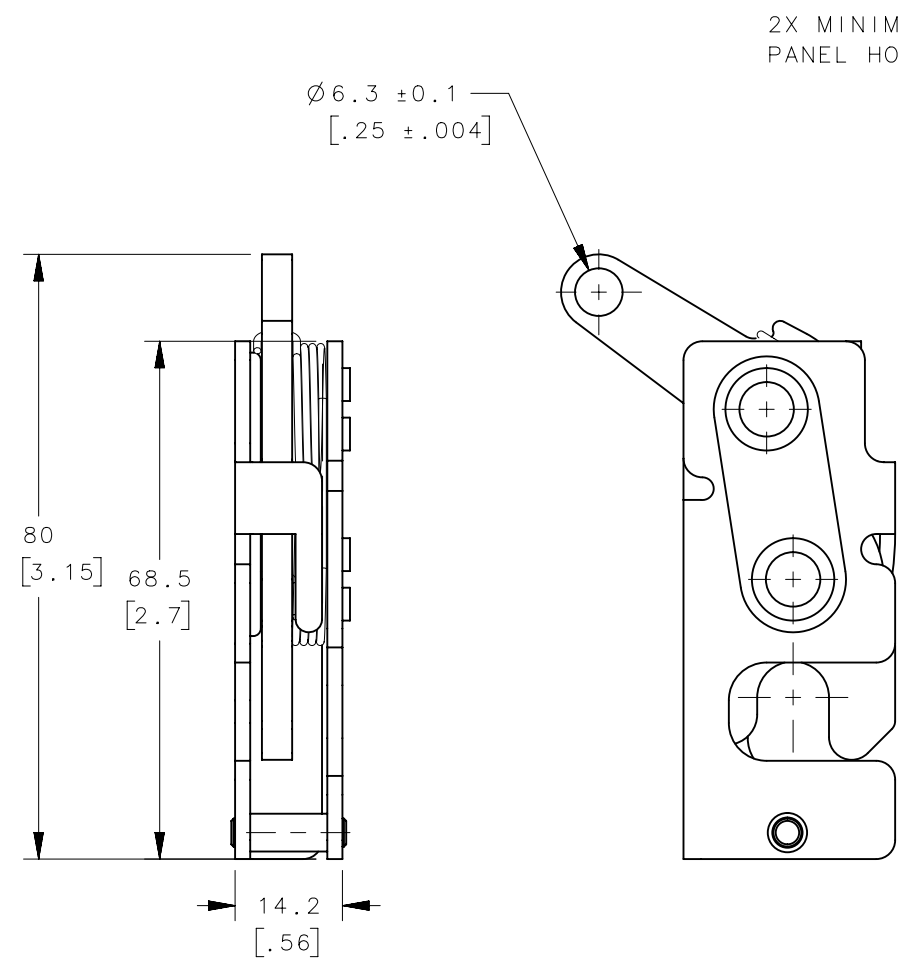
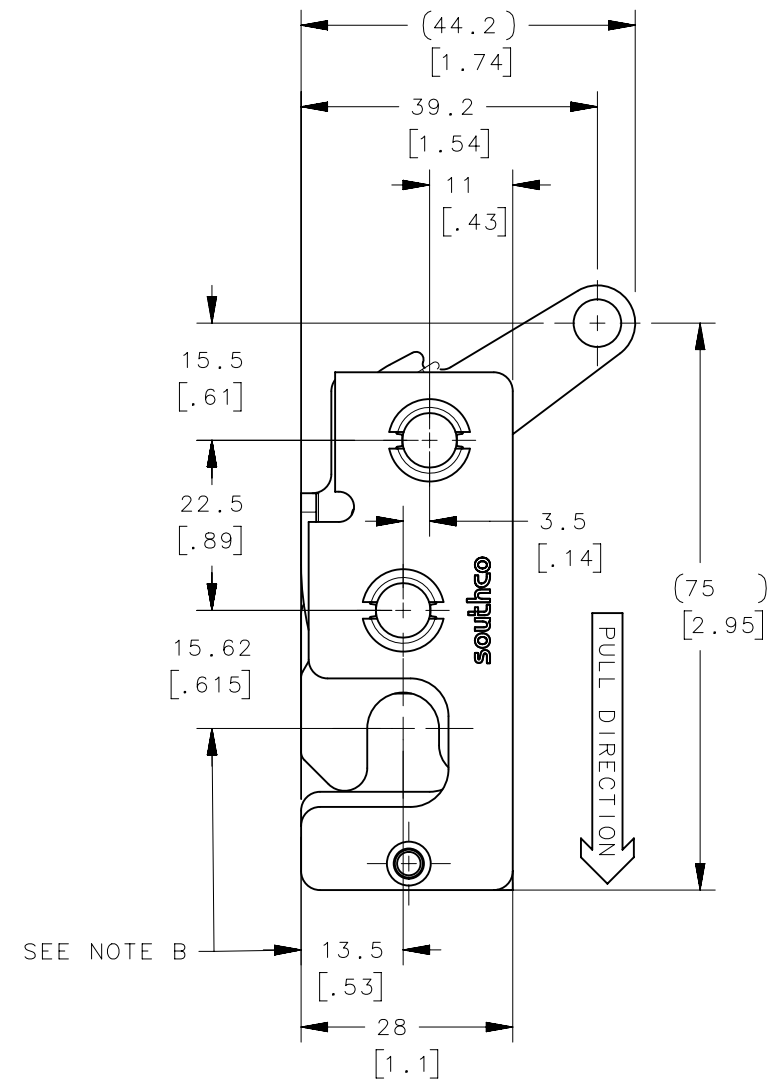

ASSEMBLY R4-10-30-501-10 SHOWN

NOTES:

A. MATERIAL AND FINISH:

- HOUSING, LEVER AND INTERNAL COMPONENTS:
MATERIAL - STEEL
-10 ZINC PLATED, BRIGHT CHROMATE
-77 ZINC NICKEL, BRIGHT CHROMATE
- PAWL AND TRIGGER:
MATERIAL - HARDENED STEEL
-10 ZINC PLATED, BRIGHT CHROMATE
-77 ZINC NICKEL, BRIGHT CHROMATE
ZINC PLATE CHROMATE.
- SPRING: STAINLESS STEEL, PASSIVATED

B. THESE DIMENSIONS REQUIRED FOR MOUNTING STRIKER BOLT.

R4-10-30-501-77	Ø 7.2mm THRU	SEE NOTE A	SEE NOTE A	
R4-10-31-501-77	1/4-20 THREAD	SEE NOTE A	SEE NOTE A	
R4-10-32-501-77	M6 THREAD	SEE NOTE A	SEE NOTE A	
R4-10-30-501-10	Ø 7.2mm THRU	SEE NOTE A	SEE NOTE A	
R4-10-31-501-10	1/4-20 THREAD	SEE NOTE A	SEE NOTE A	
R4-10-32-501-10	M6 THREAD	SEE NOTE A	SEE NOTE A	
ASSEMBLY PART NUMBER	LATCH MOUNTING HOLE	MATERIAL	FINISH	GENERAL NOTES
THIRD ANGLE PROJECTION				
MILLIMETERS [IN]				
SURFACE AREA		TOLERANCES UNLESS OTHERWISE NOTED		
VOLUME		ALL DIMENSIONS WITHOUT TOLERANCES ARE FOR REFERENCE ONLY.		
PROPRIETARY ITEM		DESCRIPTION	R4 MINI TWO STAGE ROTARY LATCH WITH TRIGGER HOLE - RIGHT HAND	
EXCEPT FOR USES EXPRESSLY GRANTED IN WRITING, INFORMATION DISCLOSED HEREON IS CONFIDENTIAL AND ALL RIGHTS, PATENT AND OTHERWISE, ARE RESERVED BY SOUTHCO, INC.		SIZE	SYSTEM	DWG NO.
PER ASME Y14.5M-1994		B	NX	J-R4-10-30-501
		DRAWN BY	DATE	SCALE
		DJK	26APR2012	1:1
		SHEET		1 OF 3

REVISION HISTORY			
REV	DATE	BY	DESCRIPTION
B	03FEB2014	ACH/ASM	PRN: P2014-0102

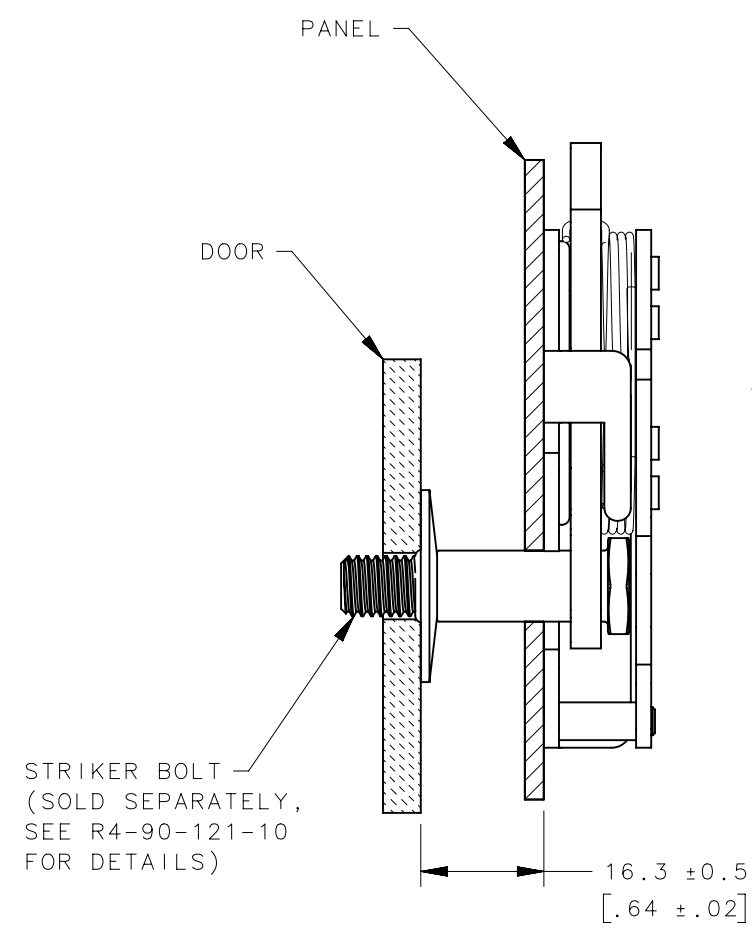

ASSEMBLY R4-10-30-501-10 SHOWN

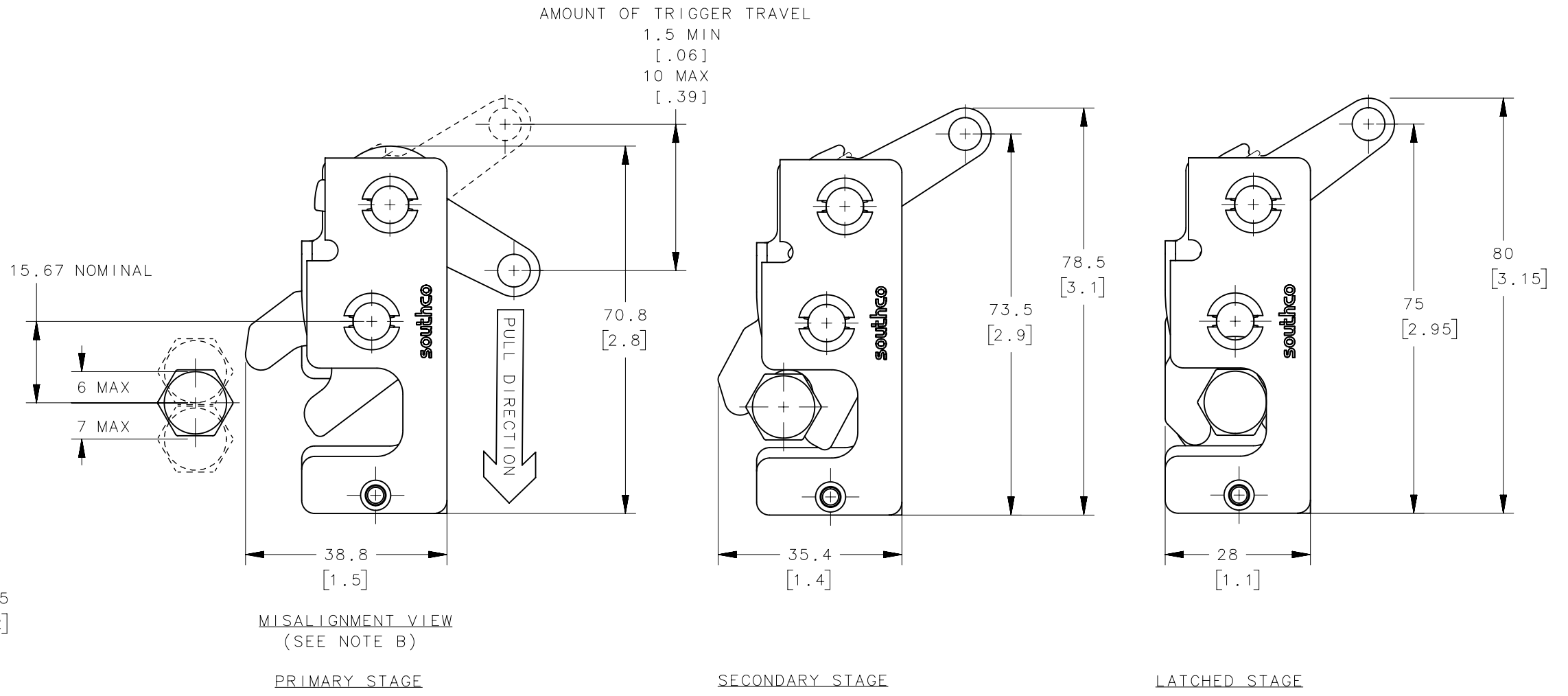

- NOTES:
- A. THE TOLERANCE BETWEEN THE LATCH AND STRIKER BOLT ASSUMES A NON-RIGID DOOR INSTALLATION THAT WILL ALLOW THE DOOR TO MOVE INTO THE NOMINAL POSITION DURING LATCHING. RIGID DOORS MUST HAVE THE STRIKER INSTALLED PER THE PANEL PREPARATION RECOMMENDATION.
 - B. THE MISALIGNMENT VIEW ASSUMES THE LATCH IS CONNECTED TO A PERFECTLY RIGID DOOR AND HINGE; THEREFORE, THERE IS NO DOOR AND/OR HINGE SLACK ASSOCIATED WITH THESE DIMENSIONS. THE MISALIGNMENT VIEW DOES NOT TAKE FLEXING OF THE STRIKER BOLT INTO ACCOUNT.

R4-10-30-501-77	∅ 7.2mm THRU	∅ 7.6 [.299]	
R4-10-31-501-77	1/4-20 THREAD	∅ 6.8 [.268]	
R4-10-32-501-77	M6 THREAD	∅ 6.4 [.252]	
R4-10-30-501-10	∅ 7.2mm THRU	∅ 7.6 [.299]	
R4-10-31-501-10	1/4-20 THREAD	∅ 6.8 [.268]	
R4-10-32-501-10	M6 THREAD	∅ 6.4 [.252]	
ASSEMBLY PART NUMBER	LATCH MOUNTING HOLE	MINIMUM RECOMMENDED PANEL HOLE	GENERAL NOTES

THIRD ANGLE PROJECTION		southco CONNECT • CREATE • INNOVATE	
MILLIMETERS [IN]			
TOLERANCES UNLESS OTHERWISE NOTED		DESCRIPTION R4 TWO STAGE MINI ROTARY LATCH WITH TRIGGER HOLE - RIGHT HAND	
ALL DIMENSIONS WITHOUT TOLERANCES ARE FOR REFERENCE ONLY.		SIZE B	SYSTEM NX
PER ASME Y14.5M-1994		DATE 26APR2012	DWG NO. J-R4-10-30-501
EXCEPT FOR USES EXPRESSLY GRANTED IN WRITING, INFORMATION DISCLOSED HEREON IS CONFIDENTIAL AND ALL RIGHTS, PATENT AND OTHERWISE, ARE RESERVED BY SOUTHCO, INC.		SCALE 1:1	SHEET 2 OF 3

6

5

4

3

2

1

REVISION HISTORY			
REV	DATE	BY	DESCRIPTION
B	03FEB2014	ACH/ASM	PRN: P2014-0102

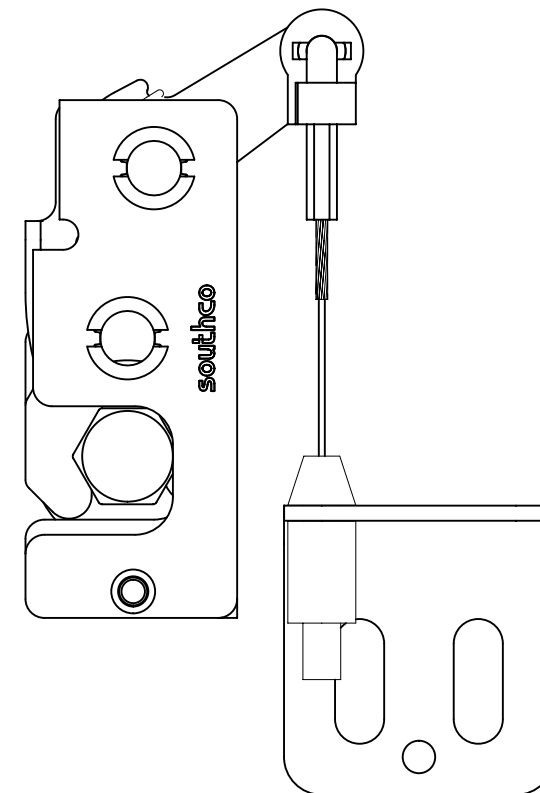
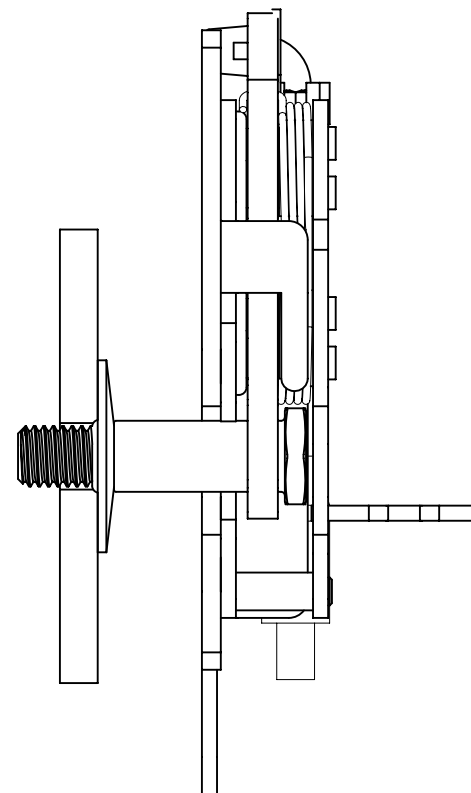
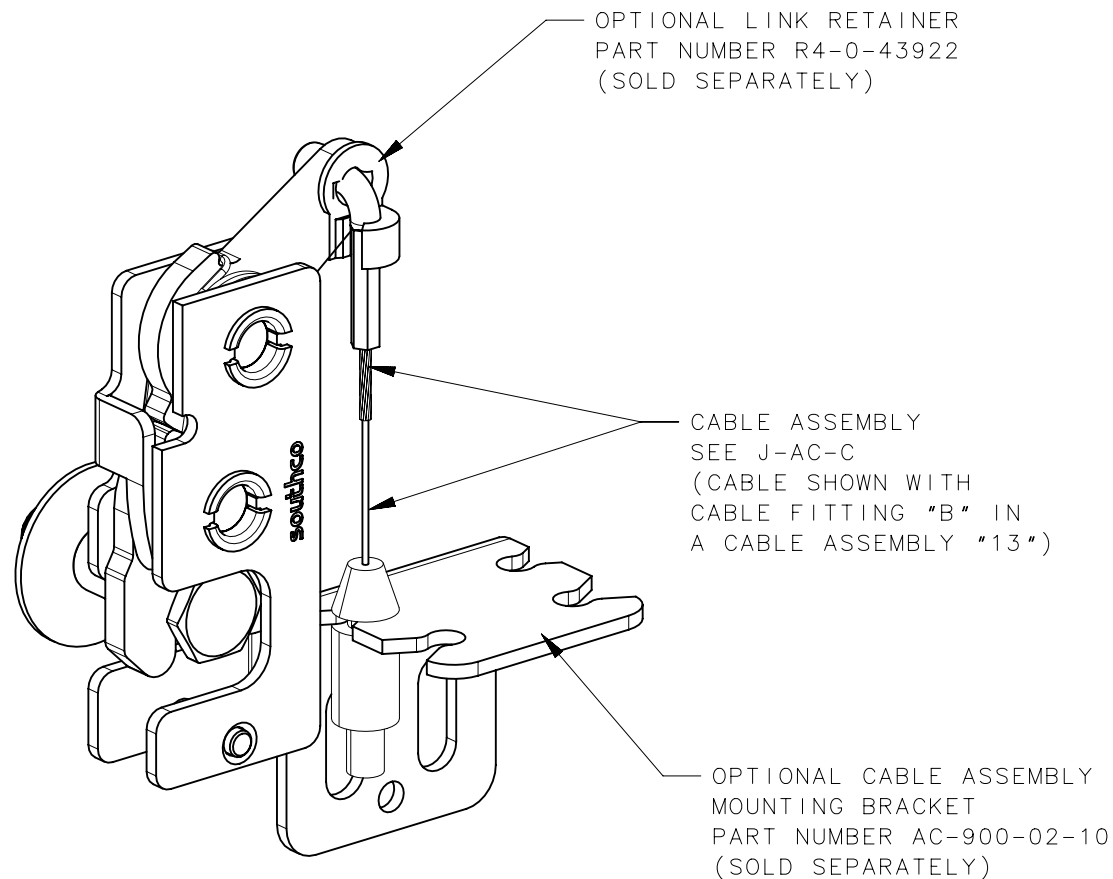

ASSEMBLY R4-10-30-501-10 SHOWN

R4-10-30-501-77	Ø 7.2mm THRU	Ø 7.6 [.299]	
R4-10-31-501-77	1/4-20 THREAD	Ø 6.8 [.268]	
R4-10-32-501-77	M6 THREAD	Ø 6.4 [.252]	
R4-10-30-501-10	Ø 7.2mm THRU	Ø 7.6 [.299]	
R4-10-31-501-10	1/4-20 THREAD	Ø 6.8 [.268]	
R4-10-32-501-10	M6 THREAD	Ø 6.4 [.252]	
ASSEMBLY PART NUMBER	LATCH MOUNTING HOLE	MINIMUM RECOMMENDED PANEL HOLE	GENERAL NOTES

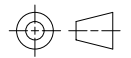
THIRD ANGLE PROJECTION				southco [®] CONNECT • CREATE • INNOVATE			
MILLIMETERS [IN]							
SURFACE AREA	TOLERANCES UNLESS OTHERWISE NOTED ALL DIMENSIONS WITHOUT TOLERANCES ARE FOR REFERENCE ONLY.			DESCRIPTION R4 TWO STAGE MINI ROTARY LATCH WITH TRIGGER HOLE - RIGHT HAND			
VOLUME							
PROPRIETARY ITEM	PER ASME Y14.5M-1994	SIZE B	SYSTEM NX	DWG NO. J-R4-10-30-501	DATE 26APR2012	SCALE 1:1	SHEET 3 OF 3
EXCEPT FOR USES EXPRESSLY GRANTED IN WRITING, INFORMATION DISCLOSED HEREON IS CONFIDENTIAL AND ALL RIGHTS, PATENT AND OTHERWISE, ARE RESERVED BY SOUTHCO, INC.		DRAWN BY DJK					

6

5

4

3

2

1