

REVISION HISTORY			
REV	DATE	BY	DESCRIPTION
D	02APR2014	MWC/YGC	PRN: P2014-0745

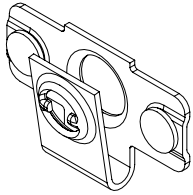

SCALE 1:1

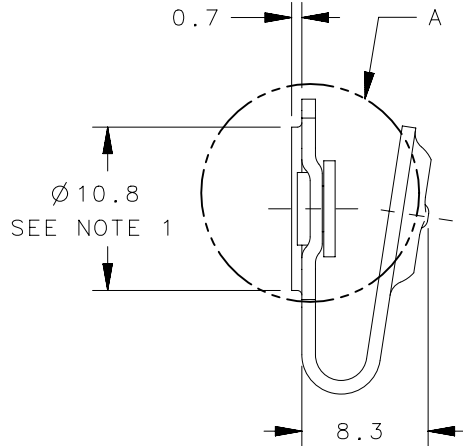
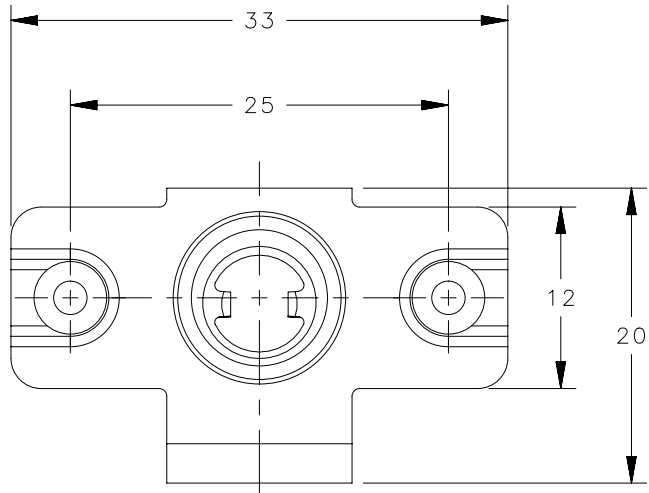

THIS COMPONENT IS UNPLATED TO ALLOW WELDING.

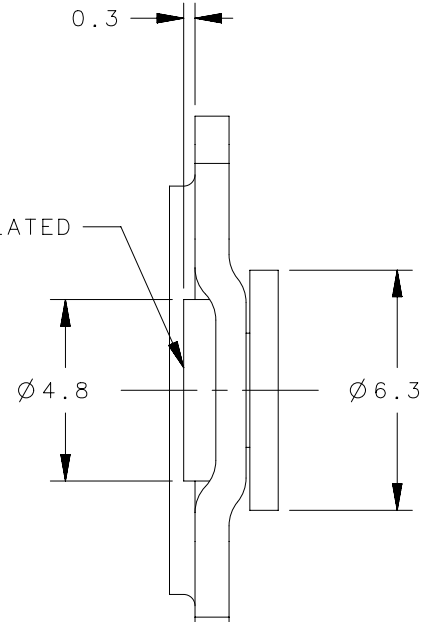

DETAIL A  
SCALE 5:1

NOTE:  
1. SUPPORT PANEL REQUIRES Ø 11.00 HOLE.

D8-336-500-130	RECEPTACLE WELD ON	CARBON STEEL	SILVER ORGANIC
D8-336-500-121	RECEPTACLE WELD ON	CARBON STEEL	SILVER GEOMET
PART NUMBER	TYPE OF COMPONENT	MATERIAL	FINISH

THIRD ANGLE PROJECTION		 CONNECT • CREATE • INNOVATE	
MILLIMETERS [IN]			
TOLERANCES UNLESS OTHERWISE NOTED		DESCRIPTION RECEPTACLE WELD ON	
ALL DIMENSIONS WITHOUT TOLERANCES ARE FOR REFERENCE ONLY.		SIZE A4	SYSTEM NX
PER ASME Y14.5M-1994		DWG NO. J-D8-336-500	DATE 20MAR2009
<small>EXCEPT FOR USES EXPRESSLY GRANTED IN WRITING, INFORMATION DISCLOSED HEREON IS CONFIDENTIAL AND ALL RIGHTS, PATENT AND OTHERWISE, ARE RESERVED BY SOUTHCO, INC.</small>		DRAWN BY MJW	SHEET 1 OF 1