

NOTES:

- A. OPERATION: 195° TURN OF KEY CAUSES PAWL TO ROTATE 75° THEN PULL UP 0.25.
 B. PAWL, NUTS, AND LOCKWASHERS SHIPPED UNASSEMBLED IN BAG WITH LATCH ASSEMBLY.
 C. INSTALLATION:
 1. INSERT LATCH INTO HOLE IN DOOR. CHECK FOR PROPER ORIENTATION AND OPERATION OF PAWL.
 2. INSTALL USING LOCKWASHER AND MOUNTING NUT (27mm ACROSS FLATS). MAX. TIGHTENING TORQUE 250 in-lb. PAWL.
 3. INSTALL JAM NUT, LOCKWASHER, PAWL, LOCKWASHER, AND JAM NUT ON SHAFT. ADJUST JAM NUTS TO POSITION PAWL AT CORRECT GRIP (WITH LATCH CLOSED). TIGHTEN JAM NUTS (180 in-lb MAX. TORQUE) USING TWO 17mm WRENCHES.
 4. CAUTION: ADJUST PAWL SO THAT NO MORE THAN 70 in-lb TORQUE ON KEY IS REQUIRED TO CLOSE LATCH.

X FINISH TABLE	
1	- BRIGHT CHROME PLATE
4	- CARDINAL WHITE POWDER COAT
5	- BLACK POWDER COAT
7	- SATIN SILVER POLYESTER POWDER COAT

southco		PROPRIETARY ITEM - EXCEPT FOR USES EXPRESSLY GRANTED IN WRITING INFORMATION DISCLOSED HEREON IS CONFIDENTIAL AND ALL RIGHTS PATENT AND OTHERWISE ARE RESERVED BY SOUTHCO, INC.		VISE-ACTION LATCH TUBULAR KEY DRIVE				DATE	DRAWN	CHKD	SCALE	DRAWING NUMBER
				5/26/89	RES		1:1	J-E3-15				
REV	DATE	DRAWN/CHKD	DESCRIPTION	ITEM	PART NUMBER	GRIP RANGE	EXTENDED GRIP RANGE	PAWL OFF-SET	INCHES ALL DIMENSIONS WITHOUT TOLERANCES ARE FOR REFERENCE ONLY. 			
G	14FEB2001	JRS	PRN: E3-847A	LATCH ASSEMBLY	E3-15-1X	0.45-1.07	2.61-3.00	1.08				
H	04MAR2003	RLR/MJS	PRN: P2003-0112	LATCH ASSEMBLY	E3-15-2X	1.00-1.62	2.07-2.69	0.54				
I	16MAY2006	RLR/MDY	PRN: P2005-1625	LATCH ASSEMBLY	E3-15-3X	1.53-2.15	NONE	NONE				
J	01MAY2007	BWR/RLR	PRN: P2007-0587									
K	11OCT2011	MJS/CMS	PRN: P2011-1307									
L	28JAN2015	CMS/MWD	PRN: P2015-0219									
M	02NOV2017	CMS/CDW	PRN: P2017-2693									
N	12FEB2021	CMS/MWD	PRN: P2021-0309									

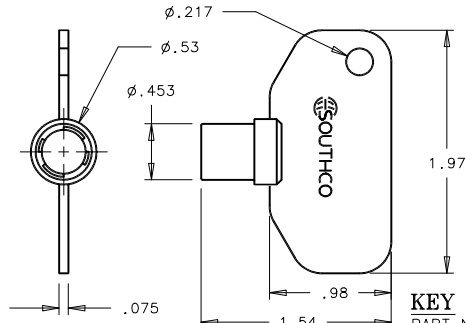

COMPONENT	MATERIAL	FINISH
HOUSING	DIE CAST ZINC	SEE FINISH TABLE
CAP	303 STAINLESS STEEL	SEE FINISH TABLE
BUSHING	ALUMINUM	SEE FINISH TABLE
RETAINER	302 STAINLESS STEEL	NATURAL
SPRING	302 STAINLESS STEEL	NATURAL
O-RING	BUNA-N	NATURAL
SLEEVE	1075 STEEL	ZINC IMMERSION COATING
CAM	1075 STEEL	ZINC IMMERSION COATING
SHAFT	LOW CARBON STEEL	ZINC PLATE CHROMATE, PLUS SEALER
PIN	1008 STEEL	ZINC PLATE, CHROMATE DIP
PAWL	1010 STEEL	ZINC PLATE CHROMATE, PLUS SEALER
JAM NUTS (2)	LOW CARBON STEEL	ZINC PLATE CHROMATE, PLUS SEALER
LOCKWASHERS (2)	SPRING STEEL	ZINC PLATE CHROMATE, PLUS SEALER
MOUNTING NUT	DIE CAST ZINC	ZINC PLATE, BRIGHT CHROMATE
MOUNTING LOCKWASHER	SPRING STEEL	ZINC PLATE CHROMATE, PLUS SEALER

KEY
 PART NUMBER E3-5-15
 TUBULAR KEY (ORDER SEPARATELY)
 DIE CAST ZINC, BRIGHT NICKEL PLATE

THE ABOVE PART NUMBERS ARE TYPE "A" (TURN CLOCKWISE TO LATCH). FOR TYPE "B" ASSEMBLIES (TURN COUNTERCLOCKWISE TO LATCH), CHANGE THE THIRD DIGIT OF THE PART NUMBER FROM 1 TO 22.
 EXAMPLE: E3-225-15

DOOR PREPARATION

METHOD A

METHOD B
 (NOT RECOMMENDED FOR GASKETED APPLICATIONS)

