

REV	DATE	DRAWN/CHKD	DESCRIPTION
A	03MAR2003	AJH/FHS	RELEASED FOR PRODUCTION
B	30MAY2003	DLH/AJH	PRN: P2003-0436
C	13JUN2003	AJH/VNI	PRN: P2003-0491
D	11AUG2003	DLH/AJH	PRN: P2003-0679

SCREW RECESS	PART NUMBER	SCREW PROJECTION		PANEL THICKNESS	
		P-1	P-2	MIN	MAX
No. 2 PHILLIPS/SLOT	4C-PS-M4-1F1-KEEE	0.6	5.6	1.5	3.2
	4C-PS-M4-2F1-KEEE	2.1	7.1		
T25 TORX®/SLOT	4C-TS-M4-1F1-KEEE	0.6	5.6	1.5	3.2
	4C-TS-M4-2F1-KEEE	2.1	7.1		

MILLIMETERS

ALL DIMENSIONS WITHOUT TOLERANCES ARE FOR REFERENCE ONLY.



A3 PAPER SIZE

MATERIAL AND FINISH:

KNOB: PC/ABS UL94 VO RATED, FLAME RETARDANT; TRIARYLPHOSPHATE (DOES NOT CONTAIN BROMINATED, CHLORINATED, OR HALOGENATED ADDITIVES).

SCREW: HEAT TREATED LOW CARBON STEEL
ZINC PLATE, CHROMATE PLUS SEALER

STANDOFF: ALUMINUM, NATURAL

SPRING: 300 SERIES STAINLESS STEEL, PASSIVATED

EEE KNOB COLOR

000 - BLACK

FOR ADDITIONAL COLORS SEE J-47-0-3

NOTES:

- GATE NOT ORIENTED WITH RECESS OR FRAME BREAK.
- FLASH HEIGHT GREATER THAN 0.3 NOT ACCEPTABLE.
- SURFACE IMPERFECTIONS: INSPECT PARTS FROM 0.6 METERS FOR 3 SECONDS. FOUR SURFACE IMPERFECTIONS MAX PER PART. SURFACE IMPERFECTIONS NO LARGER THAN 2.3mm IN DIAMETER, HEIGHT, OR WIDTH.
- KNOB AND SCREW ARE SPRING LOADED OUTWARD, AS SHOWN BELOW.

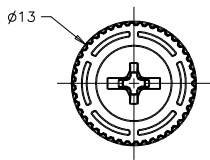

No. 2 PHILLIPS/SLOT RECESS

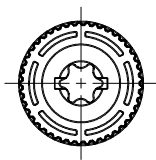

T25 TORX®/SLOT RECESS

TO INSTALL FASTENER:

- DRILL THEN COUNTERSINK AS SHOWN BELOW.
- INSERT FASTENER AND FLARE INTO COUNTERSINK WITH INSTALLATION TOOL PART NUMBER 47-108. (SEE DRAWING J-47-108 FOR FLARE TOOL DIMENSIONS).
- PUNCH CANNOT TOUCH PLASTIC DURING INSTALLATION.

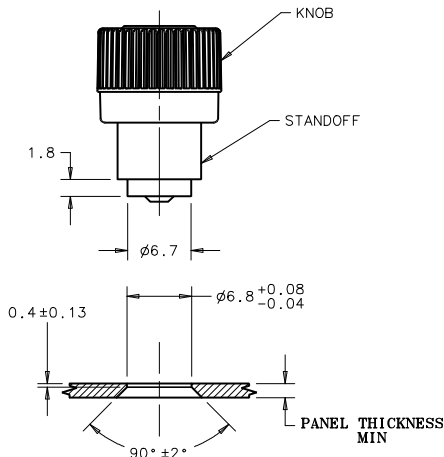

PANEL PREPARATION

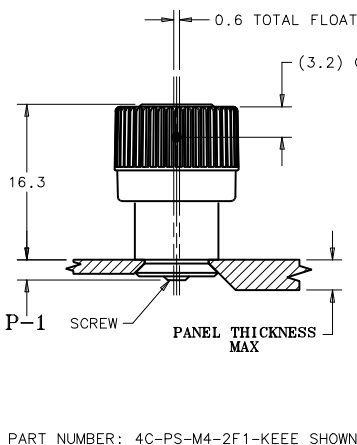

PART NUMBER: 4C-PS-M4-2F1-KEEE SHOWN

UNFASTENED

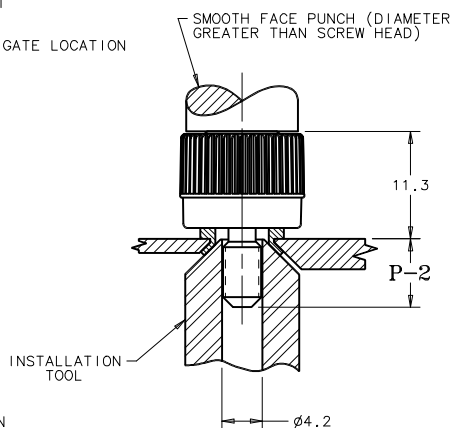

FASTENED