

REVISION HISTORY			
REV	DATE	BY	DESCRIPTION
A	11 JAN 2012	DMS/YGC	PRN: P2012-0019

OPTIONAL KEEPER PLATE
PART NUMBER K5-2811-XX

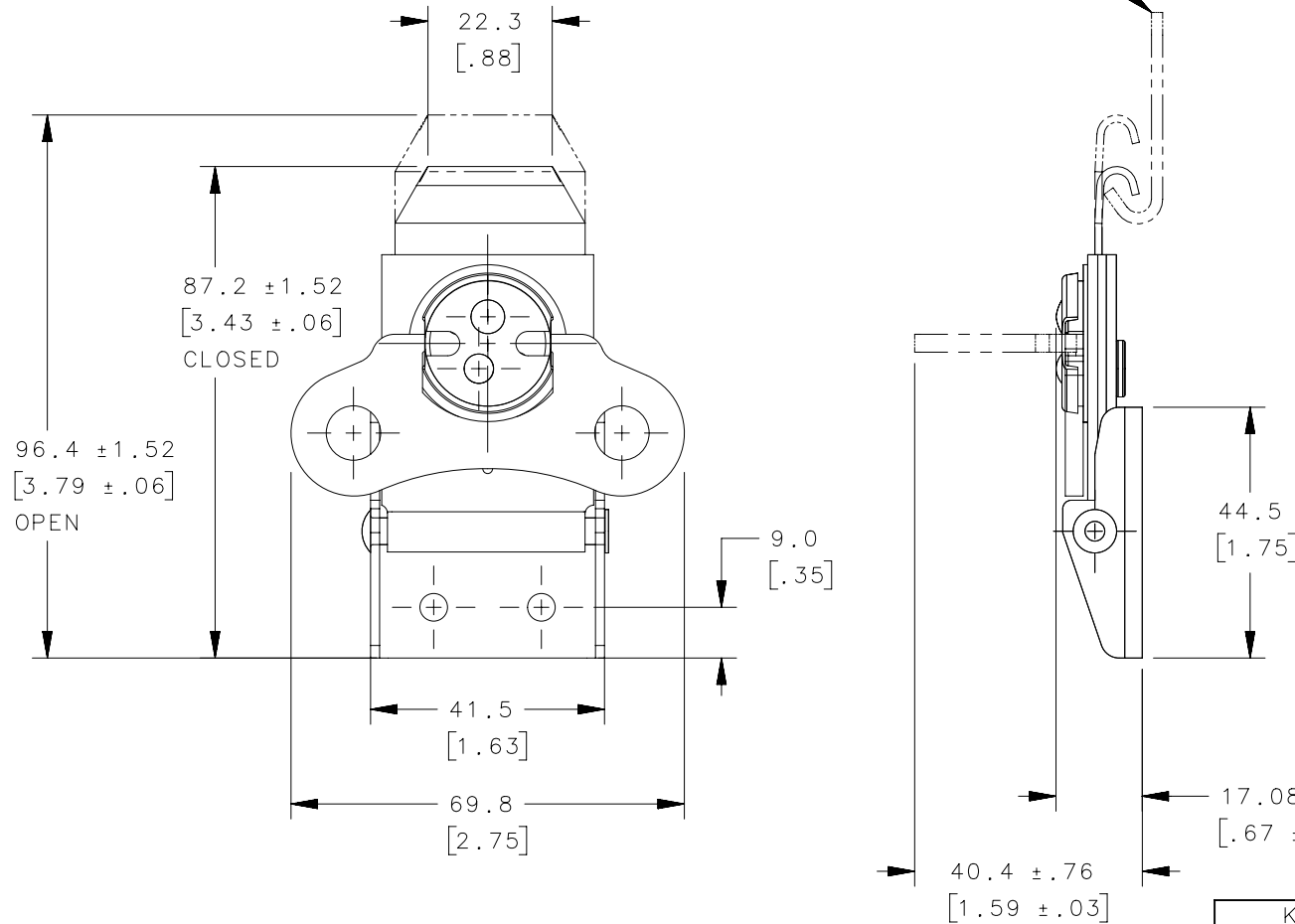

SUGGESTED PANEL PREPARATION

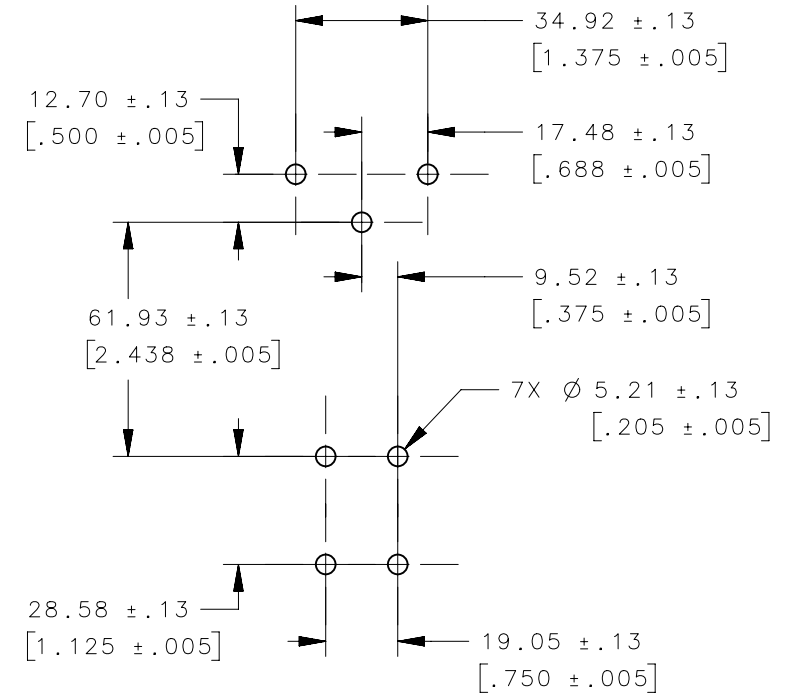

SCALE 0.5:1

K5-2857-52	STAINLESS STEEL	NATURAL
K5-2857-12	SEE NOTE A	SEE NOTE C
K5-2857-07	SEE NOTE A	SEE NOTE B
PART NUMBER	MATERIAL	FINISH

NOTE:

A. MATERIAL:

ANCHOR PLATE, WING, ANCHOR PLATE RIVET AND LOWER CAM ARE CARBON STEEL, HOUSING AND SLIDE ARE HARDENED ALLOY STEEL, CAP, CAM RIVET AND UPPER CAM ARE STAINLESS STEEL.

B. ZINC PLATE, BRIGHT CHROMATE DIP.

C. ZINC PLATE, OLIVE CHROMATE DIP.

THIRD ANGLE PROJECTION	MILLIMETERS [IN]		DESCRIPTION #2 LINK LOCK ASSEMBLY RIVET ANCHOR PLATE	
TOLERANCES UNLESS OTHERWISE NOTED		PER ASME Y14.5M-1994		DATE 25 JAN 97
ALL DIMENSIONS WITHOUT TOLERANCES ARE FOR REFERENCE ONLY.		DRAWN BY SWD/CHW		SHEET 1 OF 1
PROPRIETARY ITEM EXCEPT FOR USES EXPRESSLY GRANTED IN WRITING, INFORMATION DISCLOSED HEREON IS CONFIDENTIAL AND ALL RIGHTS, PATENT AND OTHERWISE, ARE RESERVED BY SOUTHCO, INC.		SCALE 0.75:1		

southco[®]

CONNECT • CREATE • INNOVATE