

REV.	DATE	DRAWN	REVISION	ITEM	COMPONENT	PART No	MATERIAL	FINISH	REMARKS
K	18DEC2001	JPW/JSS	PRN: P2001-0337	ASSEMBLY		B7-50-501-10			
				SLIDE ASSEMBLY		B7-10-501-10			PACKAGED ONE PER PLASTIC BAG
				HOUSING			1010 STEEL	BLACK POWDER COATING	
				SLIDE			NYLON	BLACK	
				SPRING			302 STAINLESS STEEL	PASSIVATED	
				STUD			LOW CARBON STEEL	NOTE B	
				WASHER			ACETAL	BLACK	
				TRIM PLATE		B7-33-501-10	1010 STEEL	BLACK POWDER COATING	PACKAGED ONE PER PLASTIC BAG
				LOCK ASSEMBLY		B7-21-501-10	NOTE A	NOTE A	SHIPPED BULK (2 KEYS)
				NUT-LOCKWASHER ASSY (4)		14-0-12327-05	STEEL	NOTE C	4 EACH SHIPPED IN BULK

INCH DIMENSIONS
DIMENSIONS WITHOUT TOLERANCES ARE FOR REFERENCE ONLY.

THIRD ANGLE PROJECTION
A4 PAPER SIZE

NOTES:

- A. LOCK ASSEMBLY CONSISTS OF:
CYLINDER - DIE CAST ZINC, BLACK POWDER COATING;
LOCK PAWL - 1010 STEEL, ZINC PLATE, CHROMATE PLUS SEALER;
KEYS - BRASS, NICKEL PLATED;
HEX NUT - DIE CAST ZINC, CHEMICAL PROTECTIVE FILM.
- B. ZINC PLATE, CHROMATE PLUS SEALER.
- C. ZINC PLATE, BRIGHT CHROMATE.

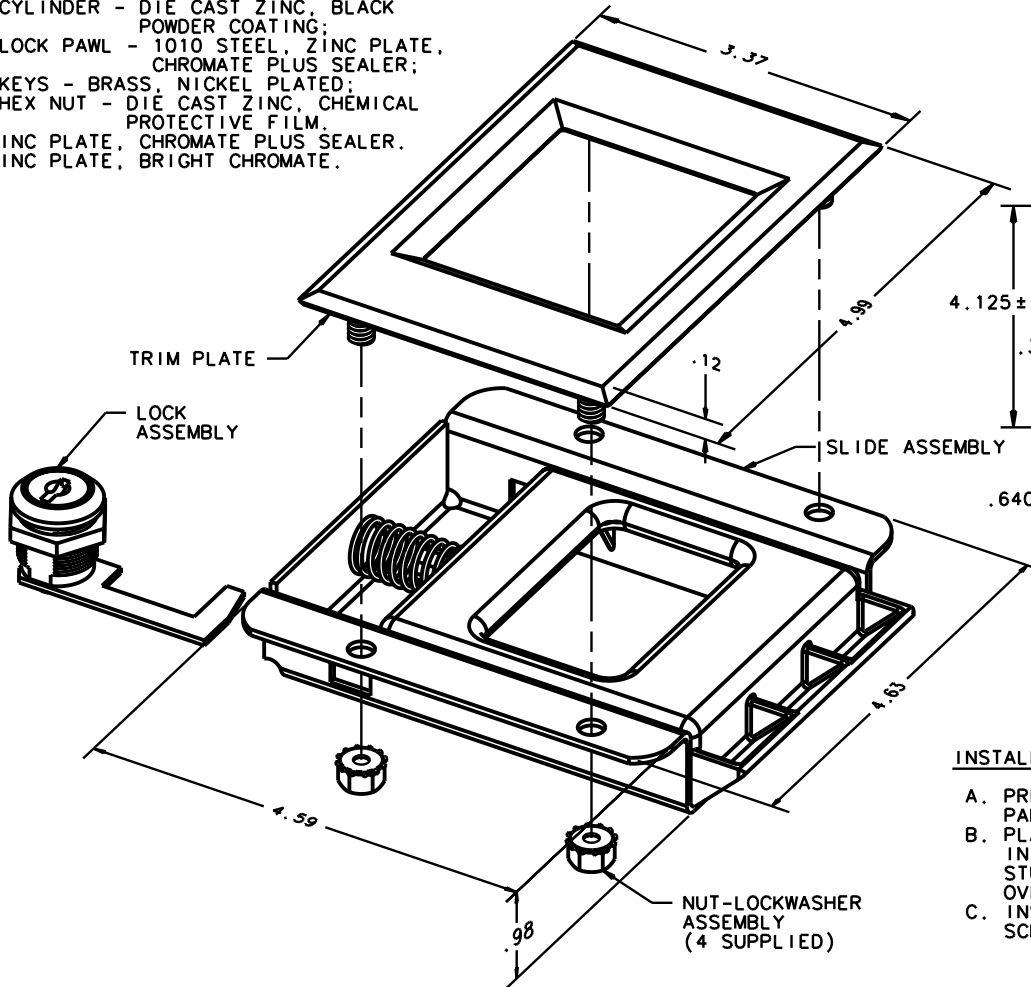

PANEL PREPARATION
SCALE .33 : 1

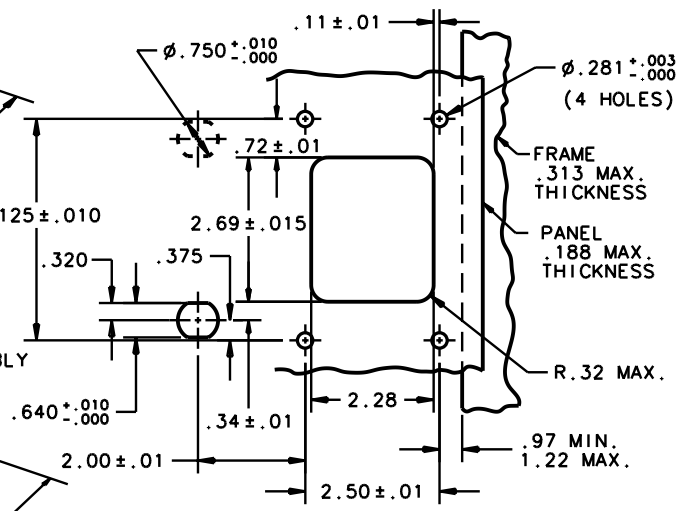

MOUNTING NOTE:
LOCK ASSEMBLY MAY BE MOUNTED ON EITHER SIDE OF FASTENER.

INSTALLATION INSTRUCTIONS:

- A. PREPARE PANEL AS SHOWN. NOTE MAX FRAME AND PANEL THICKNESSES.
- B. PLACE TRIM PLATE ASSEMBLY INTO PREPARED HOLES IN PANEL. PLACE SLIDE ASSEMBLY OVER TRIM PLATE STUDS, AS SHOWN. PLACE NUTS (PROVIDED) OVER STUDS AND TIGHTEN. CHECK FASTENER OPERATION.
- C. INSTALL LOCK AND ATTACH LOCK PAWL WITH SCREWS PROVIDED.