

REVISION HISTORY			
REV	DATE	BY	DESCRIPTION
A	11 MAR 2011	YGC	P2011-0350

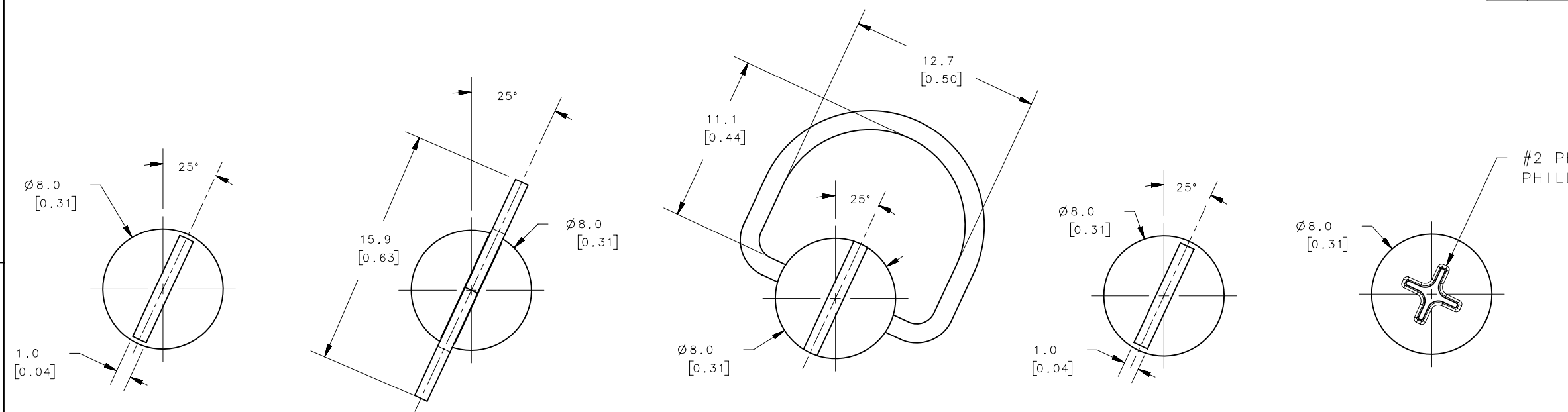

#2 PHILLIPS RECESS
PHILLIPS RECESS IS NOT ORIENTED TO CAM

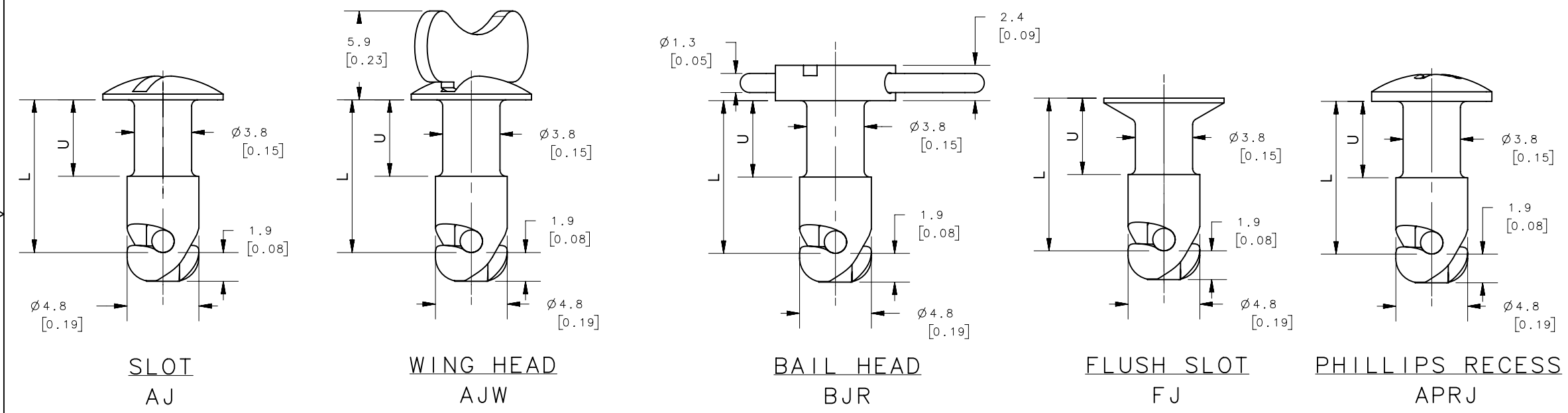

SELECTION TABLE

	K	U	L
25		1.90[0.075]	6.35[0.249]
30		2.54[0.100]	7.62[0.300]
35		3.81[0.150]	8.89[0.348]
40		5.08[0.200]	10.16[0.400]
45		5.77[0.227]	11.43[0.447]
50		6.35[0.250]	12.70[0.500]
55		6.99[0.275]	13.97[0.547]
60		7.62[0.300]	15.24[0.600]
65		8.89[0.350]	16.51[0.647]
70		8.89[0.350]	17.78[0.700]
75		9.50[0.374]	19.05[0.746]
80		10.16[0.400]	20.32[0.800]
85		10.16[0.400]	21.59[0.845]
90		12.70[0.500]	22.86[0.900]
95		12.70[0.500]	24.13[0.945]
100		12.70[0.500]	25.40[1.000]
110		12.70[0.500]	27.94[1.094]
120		12.70[0.500]	30.48[1.200]
130		12.70[0.500]	33.02[1.293]
140		12.70[0.500]	35.56[1.400]
150		12.70[0.500]	38.10[1.492]
160		12.70[0.500]	40.64[1.600]
170		12.70[0.500]	43.18[1.690]
180		12.70[0.500]	45.72[1.800]
190		12.70[0.500]	48.26[1.990]
200		12.70[0.500]	50.80[2.000]
210		12.70[0.500]	53.34[2.088]
220		12.70[0.500]	55.88[2.200]
230		12.70[0.500]	58.42[2.287]
240		12.70[0.500]	60.96[2.400]
250		12.70[0.500]	63.50[2.486]

PART NUMBER

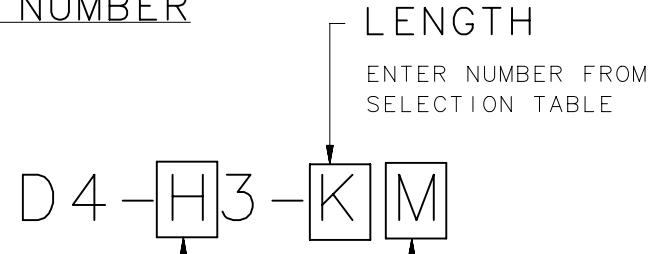

MATERIAL/FINISH

NO SUFFIX: STEEL ZINC PLATED WITH CLEAR CHROMATE FINISH
EX: D4-AJ3-30
SS: STAINLESS STEEL, HEAT TREATED, PASSIVATED
EX: D4-AJ3-30SS
FOR OTHER NON STANDARD FINISHES, REFER TO SOUTHCO
SPECIFICATION J-D5-0-3.
EX: D4-AJ3-30CBB

HEAD STYLE

- AJ SLOT
- AJW WING HEAD
- BJR BAIL HEAD
- FJ FLUSH SLOT
- APRJ PHILIPS RECESS

THIRD ANGLE PROJECTION			southco [®] CONNECT • CREATE • INNOVATE		
					DESCRIPTION QUARTER TURN FASTENER, D4-H3
MILLIMETERS [IN]	TOLERANCES UNLESS OTHERWISE NOTED ALL DIMENSIONS WITHOUT TOLERANCES ARE FOR REFERENCE ONLY.		SIZE A3	SYSTEM NX	DWG NO. J-D4-H3-K
PROPRIETARY ITEM <small>EXCEPT FOR USES EXPRESSLY GRANTED IN WRITING, INFORMATION DISCLOSED HEREON IS CONFIDENTIAL AND ALL RIGHTS, PATENT AND OTHERWISE, ARE RESERVED BY SOUTHCO, INC.</small>	PER ASME Y14.5M-1994	DRAWN BY YGC	DATE 08 DEC 2010	SCALE 3:1	SHEET 1 OF 1