

DATE	DRAWN	CHKD	SCALE	DRAWING NUMBER
23SEP92	JGK		1:1	J-19-93-10

REV.	DATE	BY-CHKD	REVISIONS	ITEM	COMPONENT	PART No.	MATERIAL	FINISH
A	02JAN2002	DLH	PRN: P2002-0764	ASSEMBLY		19-93-10		
B	26JUL2012	CMS BGL	PRN: P2012-0986	HANDLE-SHAFT SUB-ASSEMBLY				
C	22AUG2016	JPK CMS	PRN: P2016-1936	HANDLE			NYLON	BLACK
				SCREW			DIE CAST ZINC	BLACK CHROMATE
				PIN			18-9LW STAINLESS STEEL	SEE NOTE A
				BUSHING			IR/BR RUBBER	BLACK
				NUT			NYLON	BLACK
				CUP			NYLON	BLACK
				BRACKET			302 STAINLESS STEEL	PASSIVATED
				RETAINING RING			SPRING STEEL	ZINC PLATE- YELLOW CHROMATE

INSTALLATION

1. PREPARE RECTANGULAR HOLE IN DOOR AND ROUND HOLE IN FRAME.
2. SEAT LATCH IN RECTANGULAR HOLE.
3. POSITION BRACKET AND RETAINER OVER STUD. PLACE SET TOOL OVER RETAINER AND SHARPLY STRIKE TOOL * WITH HANDLE IN UP (UNLATCHED) POSITION, ADJUST NUT TO PROVIDE SATISFACTORY LATCHING TENSION.

NOTE A: PASSIVATED WITH BLACK OXIDE COATING.

* SOUTHCO TOOL No.17-10019-11 MUST BE ORDERED SEPARATELY.

RECOMMENDED FRAME HOLE DIAMETERS

FRAME THICKNESS	HOLE DIAMETER
UP TO 3.2	13.5 ^{+0.5} _{-0.0}
3.2 TO 4.8	14 ^{+0.5} _{-0.0}

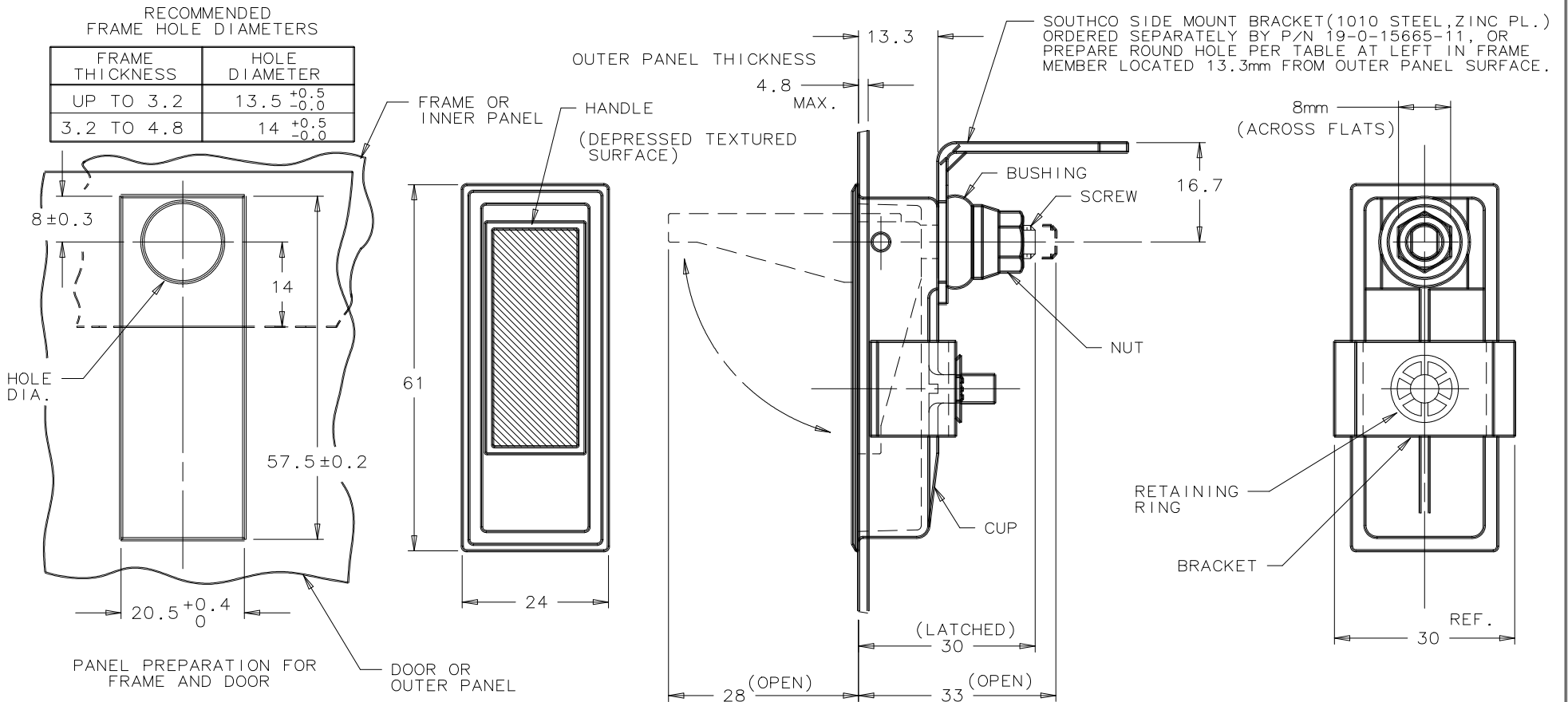

FORMAT A 3/88

PROPRIETARY ITEM - EXCEPT FOR USES EXPRESSLY GRANTED IN WRITING
INFORMATION DISCLOSED HEREON IS CONFIDENTIAL AND ALL RIGHTS PATENT
AND OTHERWISE ARE RESERVED BY SOUTHCO, INC.

THIRD ANGLE PROJECTION
ALL DIMENSIONS ARE IN MILLIMETRES
DIMENSIONS WITHOUT TOLERANCES ARE FOR REFERENCE ONLY.

DRAWING NUMBER
J-19-93-10