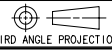

REV	DATE	DRAWN/CHKD	DESCRIPTION	SCREW RECESS	PART NUMBER	SCREW PROJECTION		PANEL THICKNESS		B	L	MILLIMETERS
						P-1	P-2	A MIN	A MAX			
A	03MAR2003	AJH/FHS	RELEASED FOR PRODUCTION	No. 2 PHILLIPS/SLOT	4C-PS-M4-3T2-KEEE	3.8	8.8	0.8	1.6	3.1	4.0	ALL DIMENSIONS WITHOUT TOLERANCES ARE FOR REFERENCE ONLY.
B	30MAY2003	DLH/AJH	PRN: P2003-0436		4C-PS-M4-4T2-KEEE	5.4	10.4					
C	11AUG2003	DLH/AJH	PRN: P2003-0679		4C-PS-M4-3T3-KEEE	3.8	8.8					
D	26MAR2004	AAB/RLR	PRN: P2004-0309		4C-PS-M4-4T3-KEEE	5.4	10.4					
				T25 TORX®/SLOT	4C-TS-M4-3T2-KEEE	3.8	8.8	0.8	1.6	3.1	4.0	 B PAPER SIZE
					4C-TS-M4-4T2-KEEE	5.4	10.4					
					4C-TS-M4-3T3-KEEE	3.8	8.8					
					4C-TS-M4-4T3-KEEE	5.4	10.4					

MATERIAL AND FINISH:

KNOB: PC/ABS UL94 VO RATED, FLAME RETARDANT; TRIARYLPHOSPHATE (DOES NOT CONTAIN BROMINATED, CHLORINATED, OR HALOGENATED ADDITIVES).
 SCREW: HEAT TREATED LOW CARBON STEEL ZINC PLATE, CHROMATE PLUS SEALER
 STANDOFF: ALUMINUM, NATURAL
 SPRING: 300 SERIES STAINLESS STEEL, PASSIVATED
 WASHER: 300 SERIES STAINLESS STEEL, PASSIVATED

"EEE" KNOB COLOR
 000 - BLACK
 FOR ADDITIONAL COLORS SEE J-47-0-3

- NOTES:
- GATE NOT ORIENTED WITH RECESS OR FRAME BREAK.
 - FLASH HEIGHT GREATER THAN 0.3 NOT ACCEPTABLE.
 - SURFACE IMPERFECTIONS: INSPECT PARTS FROM 0.6 METERS FOR 3 SECONDS. FOUR SURFACE IMPERFECTIONS MAX PER PART. SURFACE IMPERFECTIONS NO LARGER THAN 2.3mm IN DIAMETER, HEIGHT, OR WIDTH.
 - KNOB AND SCREW ARE SPRING LOADED OUTWARD, AS SHOWN BELOW.

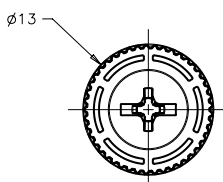

No. 2 PHILLIPS/SLOT RECESS

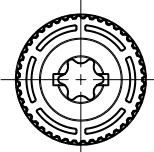

T25 TORX®/SLOT RECESS

TO INSTALL FASTENER:

- DRILL OR PUNCH HOLE AS SHOWN BELOW.
- PLACE FERRULE INTO INSTALLATION HOLE.
- CENTER TOOL ON THE SCREW THREAD, THEN ROLL FERRULE OVER WASHER TO CAPTIVATE THE ASSEMBLY.
- PUNCH CANNOT TOUCH PLASTIC DURING INSTALLATION.

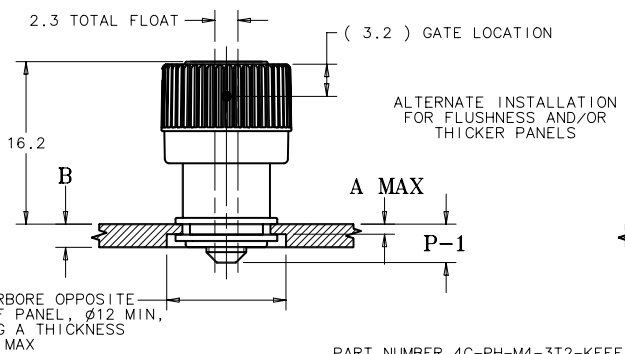
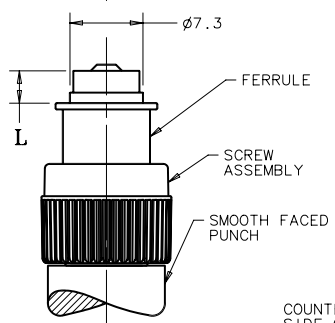
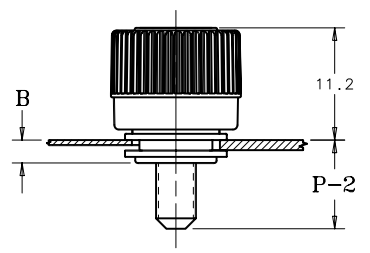
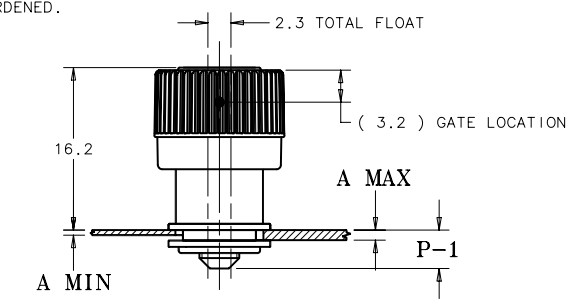
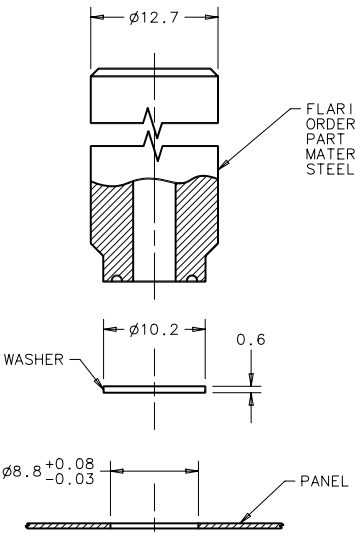

PANEL PREPARATION

PART NUMBER 4C-PH-M4-3T2-KEEE SHOWN