

| REVISION HISTORY | | | |
|------------------|-----------|---------|-----------------|
| REV | DATE | BY | DESCRIPTION |
| H | 19JUL2022 | PSP/DMS | PRN: P2022-1308 |

Ø HOLE DIAMETER ±0.10

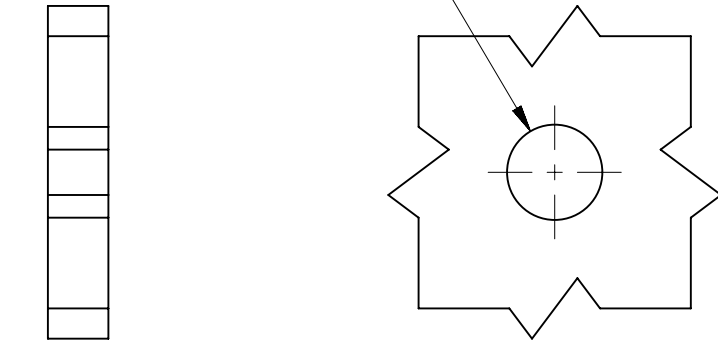

PANEL THICKNESS +0.20
-0.10

RECOMMENDED PANEL PREPARATION DIMENSIONS
SCALE 2:1

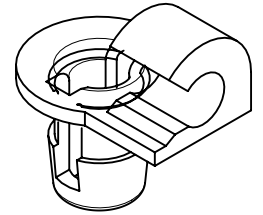
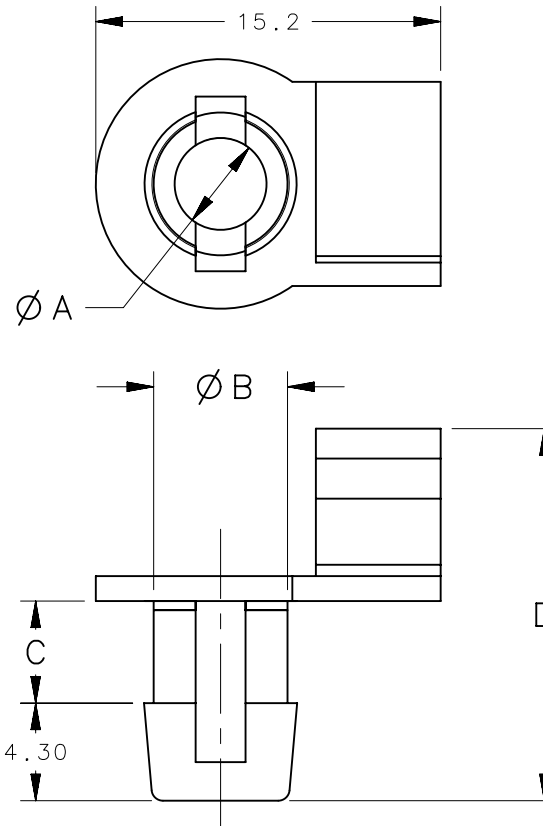

SCALE 2:1

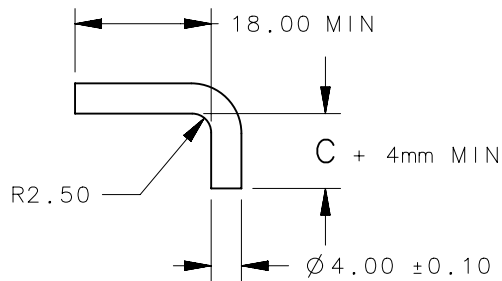
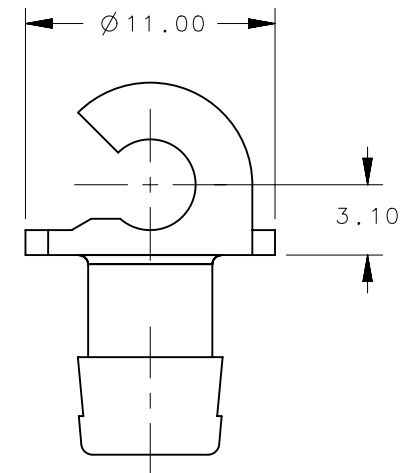

RECOMMENDED L FITTING DIMENSIONS FOR
ROD OR CABLE ACTUATED APPLICATIONS
SCALE 1:1

| R4-0-43922-4 | RETAINER | NYLON | M-53-10 OR 00-120-4967(BLUE) | 4.05 | 5.9 | 2.5 | 14.4 | 6.30 | 2.0 |
|----------------|-------------------|----------|-------------------------------|------------|-----|-----|-------------------|---------------|-----------------|
| R4-0-43922-3 | RETAINER | ACETAL | PANTONE 200C RED | 4.05 | 5.9 | 2.5 | 14.4 | 6.30 | 2.0 |
| R4-0-43922-2 | RETAINER | ACETAL | BLACK | 4.05 | 5.9 | 4.5 | 16.4 | 6.30 | 4.0 |
| R4-0-43922-1 | RETAINER | ACETAL | NATURAL | 4.05 | 6.3 | 4.5 | 16.4 | 6.65 | 4.0 |
| R4-0-43922 | RETAINER | ACETAL | BLACK | 4.05 | 5.9 | 2.5 | 14.4 | 6.30 | 2.0 |
| PART NUMBER | TYPE OF COMPONENT | MATERIAL | FINISH | A | B | C | D | HOLE DIAMETER | PANEL THICKNESS |
| SPECIFICATIONS | | | | DIMENSIONS | | | PANEL PREPARATION | | |

| | | | | | | | | | |
|--|--|------------------------------|--------------|-------------------------|--|--------------|--|-----------------|--|
| THIRD ANGLE PROJECTION | | | | | | | | | |
| MILLIMETERS [IN] | | | | | | | | | |
| TOLERANCES UNLESS OTHERWISE NOTED | | DESCRIPTION LINK RETAINER | | | | | | | |
| ALL DIMENSIONS WITHOUT TOLERANCES ARE FOR REFERENCE ONLY. | | SIZE A4 | SYSTEM NX | DWG NO. J-R4-0-43922 | | | | | |
| PER ASME Y14.5M-1994 | | DRAWN BY ACH | | DATE 28APR2009 | | SCALE 3:1 | | SHEET 1 OF 1 | |
| <small>PROPRIETARY ITEM EXCEPT FOR USES EXPRESSLY GRANTED IN WRITING, INFORMATION DISCLOSED HEREON IS CONFIDENTIAL AND ALL RIGHTS, PATENT AND OTHERWISE, ARE RESERVED BY SOUTHCO, INC.</small> | | | | | | | | | |