

REVISION HISTORY			
REV	DATE	BY	DESCRIPTION
E	02APR2019	MJS/CDW	PRN: P2019-0711

SOUTHCO PERFORMANCE GUIDELINES:

THE PERFORMAMCE GUIDELINES SHOWN ON THIS PAGE ARE SUPPLIED AS A GENERAL GUIDE ONLY, AS CONDITIONS VARY WITH EACH APPLICATION AND METHOD OF INSTALLATION, STRENGTH DATA GIVEN IS FOR FAILURE OF THE PRODUCT OR FOR SUFFICIENT DEFORMATION TO MAKE THE PRODUCT INOPERABLE. NO SAFETY FACTOR HAS BEEN APPLIED IT IS RECOMMENDED THAT THE USER REQUEST A PRODUCT SAMPLE FOR TESTING TO DETERMINE THE SUITABILITY OF THE PRODUCT FOR THE PURPOSE INTENDED AND USER'S PARTICULAR APPLICATION.

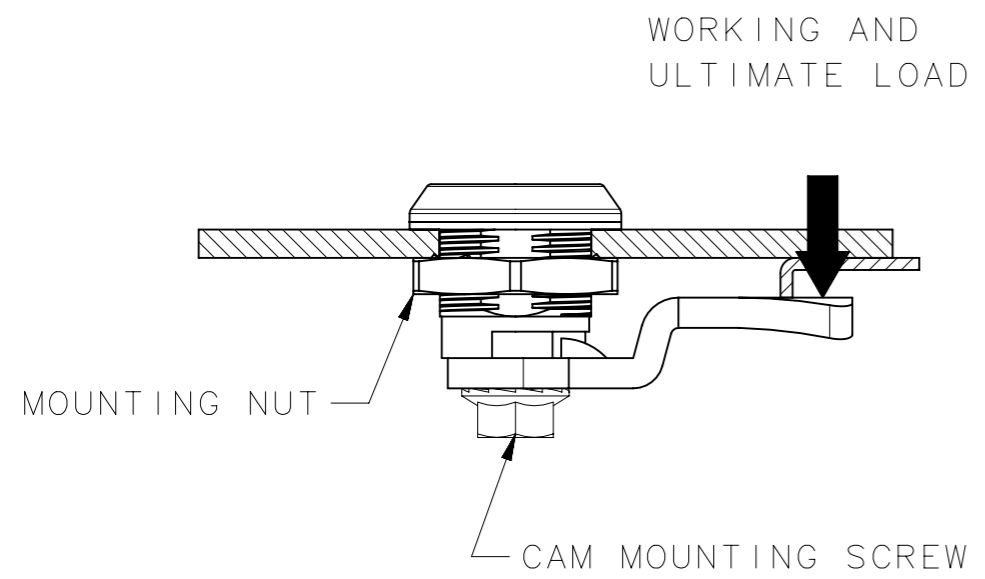

TEST DESCRIPTION	E5-5-WWX-YY1-ZZ	E5-6-WW2-YY1
MAXIMUM RECOMMENDED WORKING LOAD ①	330 N	330 N
AVERAGE ULTIMATE LOAD ②	450 N	450 N
MAXIMUM RECOMMENDED MOUNTING NUT TIGHTENING TORQUE	10 N-m	10 N-m
MAXIMUM RECOMMENDED CAM SCREW TIGHTENING TORQUE	5 N-m	5 N-m
CYCLE LIFE	5,000 AT 18 N	5,000 AT 67 N

NOTES:

- ① WORKING LOAD IS THE MAXIMUM FORCE THAT THE PRODUCT WILL WITHSTAND WITHOUT AFFECTING THE OPERATION OR APPEARANCE..
- ② AVERAGE ULTIMATE LOAD CAUSES FAILURE OF THE PRODUCT OR SUFFICIENT DEFORMATION TO MAKE THE PRODUCT INOPERABLE.

REF: trE5-19, trE5-24

THIRD ANGLE PROJECTION		southco [®] CONNECT • CREATE • INNOVATE	
MILLIMETERS [IN]			
TOLERANCES UNLESS OTHERWISE NOTED		DESCRIPTION	
UP TO 0.5 ±0.05		TOOL AND KEY OPERATED E5 QUAD LATCH, DIE CAST	
OVER 0.5 UP TO 6 ±0.1			
OVER 6 UP TO 30 ±0.2			
OVER 30 ±0.3			
ANGLES ±1°		SIZE	SYSTEM
PROPRIETARY ITEM		A3	NX
EXCEPT FOR USES EXPRESSLY GRANTED IN WRITING, INFORMATION DISCLOSED HEREON IS CONFIDENTIAL AND ALL RIGHTS, PATENT AND OTHERWISE, ARE RESERVED BY SOUTHCO, INC.		DWG NO.	TD-E5-2-J
PER ASME Y14.5M-1994		DRAWN BY	GM/SP
		DATE	22AUG2002
		SCALE	1:1
		SHEET	1 OF 1