

REV	DATE	DRAWN/CHKD	DESCRIPTION
A	19MAY2000	GDM	SEE RECORD PRINT
B	09APR2002	GDM	UPDATE FORMAT

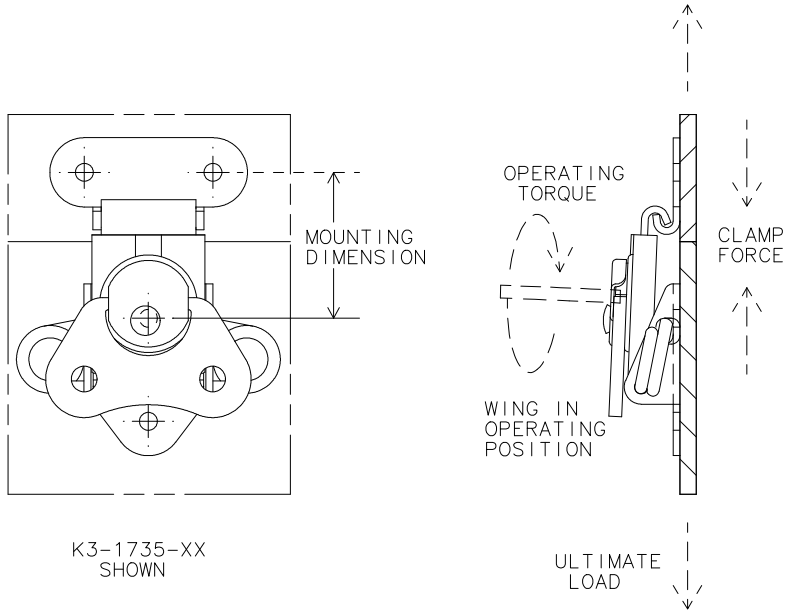

SOUTHCO PERFORMANCE GUIDELINES

THE PERFORMANCE GUIDELINES SHOWN ON THIS PAGE ARE SUPPLIED AS A GENERAL GUIDE ONLY, AS CONDITIONS VARY WITH EACH APPLICATION AND METHOD OF INSTALLATION. STRENGTH DATA GIVEN IS FOR FAILURE OF THE PRODUCT OR FOR SUFFICIENT DEFORMATION TO MAKE PRODUCT INOPERABLE. NO SAFETY FACTOR HAS BEEN APPLIED. IT IS RECOMMENDED THAT THE USER REQUEST A PRODUCT SAMPLE FOR TESTING TO DETERMINE THE SUITABILITY OF THE PRODUCT FOR THE PURPOSE INTENDED AND USER'S PARTICULAR APPLICATION.



PART NUMBERS	MOUNTING DIMENSION mm(inch)	CLAMP FORCE (A) N(lbf)	OPERATING TORQUE (B) N·m(lbf·in)	ULTIMATE LOAD (C) N(lbf)
LATCH K3-1625-07 KEEPER K3-0334-07	27 (1.063)	365 (82)	2.8 (25)	2166 (487) (1)
LATCH K3-1625-52 KEEPER K3-0334-52	27 (1.063)	409 (92)	2.5 (22)	2340 (526) (1)
LATCH K3-1735-07 KEEPER K3-0334-07	27 (1.063) MINIMUM 30 (1.18) MAXIMUM	378 (85) 957 (215)	2.9 (26) 5.1 (45)	2270 (510) (2)

- A) CLAMP FORCE IS THE FORCE EXERTED ON THE MOUNTING PANELS BY THE LATCH AND KEEPER.
- B) OPERATING TORQUE IS THE TORQUE REQUIRED ON THE WING TO FULLY ENGAGE THE LATCH.
- C) ULTIMATE LOAD IS THE MAXIMUM LOAD THE ASSEMBLY CAN WITHSTAND BEFORE FAILURE OCCURS.
 - 1) FAILURE DUE TO EXCESSIVE BENDING OF LATCHING ARM AND KEEPER.
 - 2) FAILURE DUE TO LATCHING ARM PULLING OFF OF SPRING.