

REVISION HISTORY			
REV	DATE	BY	DESCRIPTION
B	15JUN2016	VK/YGC	PRN: P2016-1381

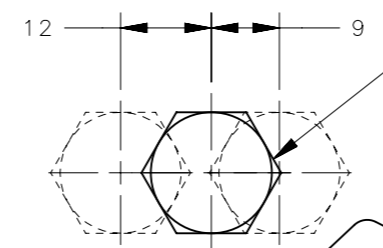

STRIKER BOLT  
PART NUMBER R4-91-2X1-10  
(SOLD SEPARATELY  
SEE DRAWING J-R4-91-200 FOR DETAILS)

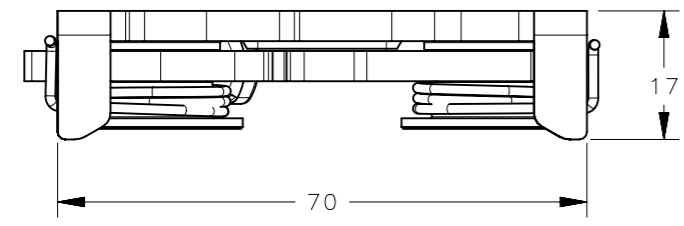
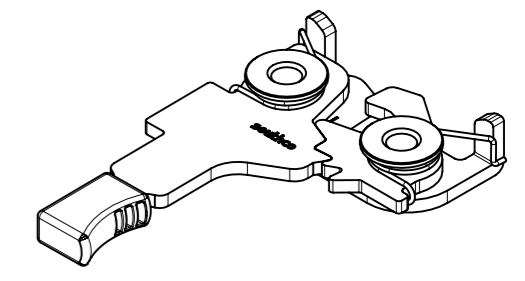

SCALE 1:2

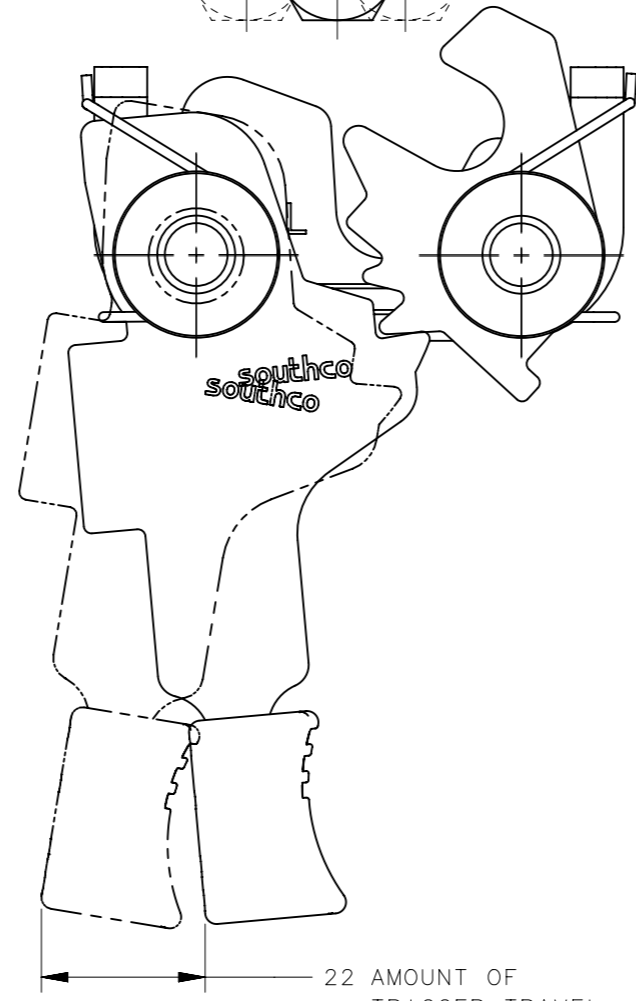
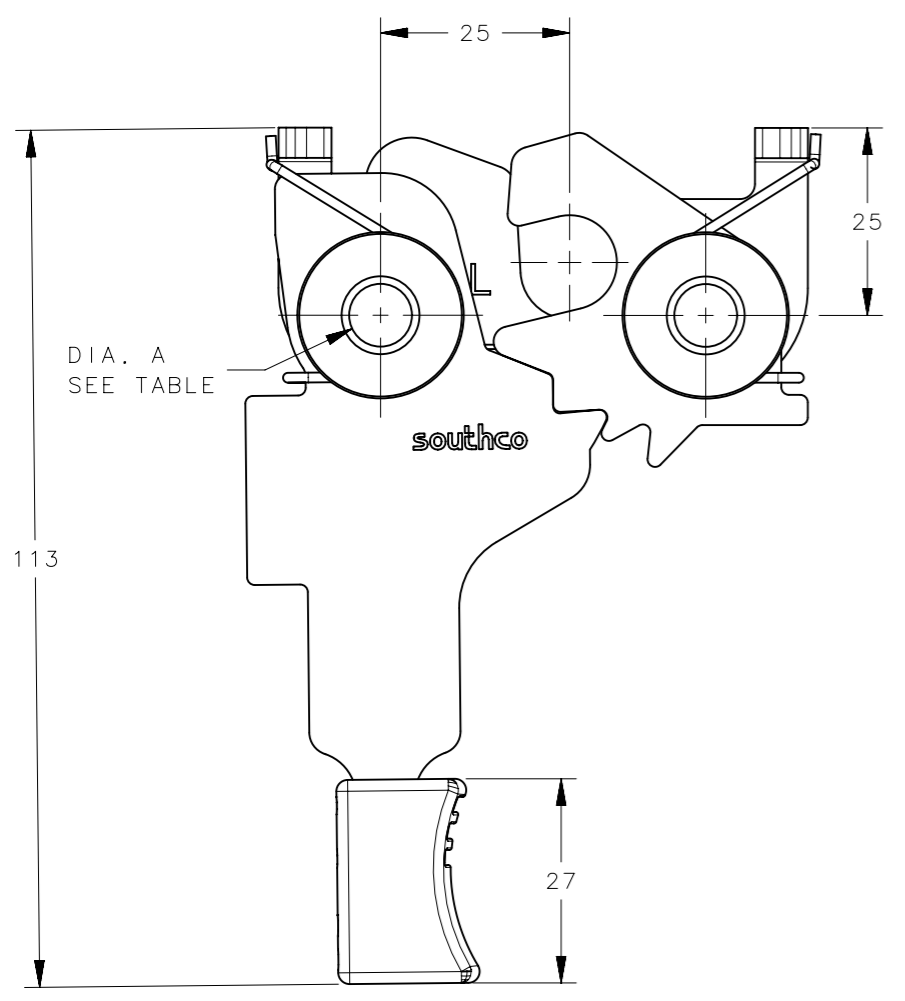

MISALIGNMENT VIEW  
(SEE NOTE 2)

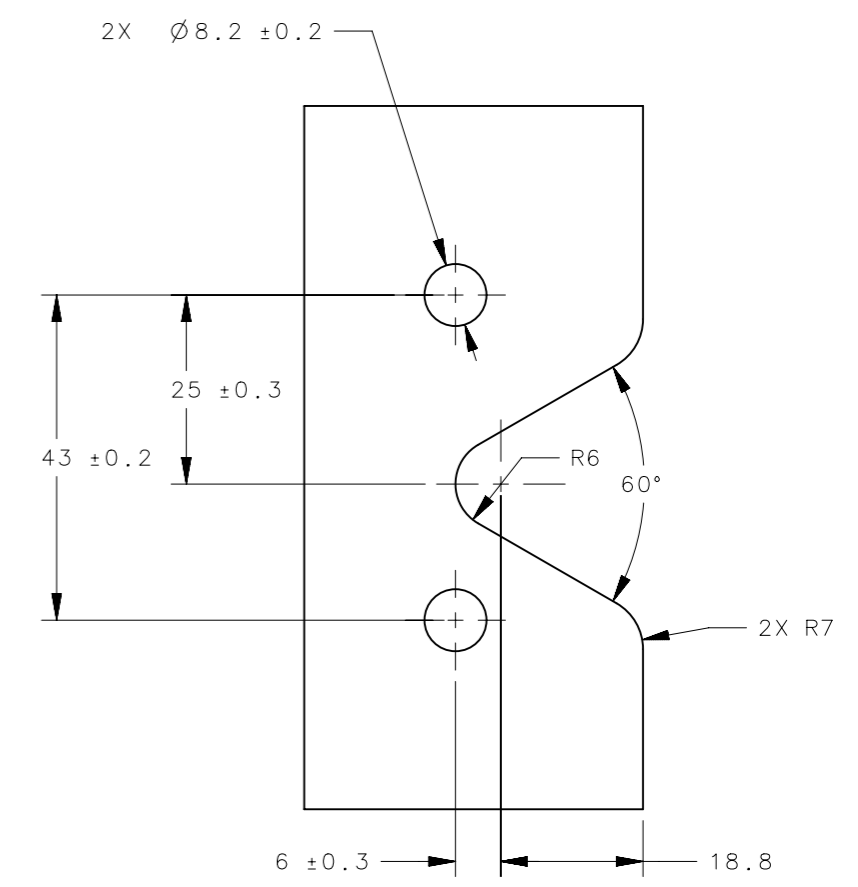
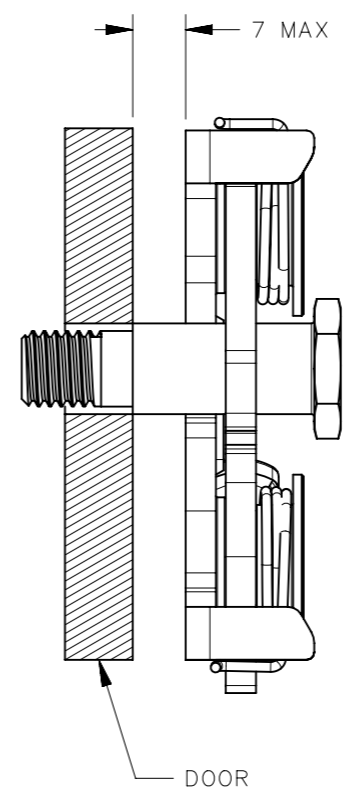

PANEL PREPARATION

- NOTES:
- MATERIAL AND FINISH:
    - A. HOUSING AND PIN: STEEL, ZINC PLATED, BRIGHT CHROMATE
    - B. PAWL AND TRIGGER: HARDENED STEEL, ZINC PLATED BRIGHT CHROMATE.
    - C. SPRING: STAINLESS STEEL, PASSIVATED
  - THE TOLERANCE BETWEEN THE LATCH AND STRIKER BOLT ASSUMES A NON-RIGID DOOR INSTALLATION THAT WILL ALLOW THE DOOR TO MOVE INTO THE NOMINAL POSITION DURING LATCHING. RIGID DOORS MUST HAVE THE STRIKER INSTALLED PER THE PANEL PREPERATION RECOMMENDATION.

R4-20-42-401-10	M8 ASSEMBLY	M8 X 1.25	SEE NOTE 1	SEE NOTE 1
R4-20-41-401-10	5/16-18 ASSEMBLY	5/16-18 THREAD	SEE NOTE 1	SEE NOTE 1
R4-20-40-401-10	8.3mm THRU ASSEMBLY	Ø 8.3 ± .12	SEE NOTE 1	SEE NOTE 1
PART NUMBER	ITEM	DIMENSION A	MATERIAL	FINISH
THIRD ANGLE PROJECTION				
MILLIMETERS [IN]				
TOLERANCES UNLESS OTHERWISE NOTED		DESCRIPTION		
ALL DIMENSIONS WITHOUT TOLERANCES ARE FOR REFERENCE ONLY.		R4-20 LEFT HAND ASSEMBLY DUAL STAGE WITH HANDLE		
PROPRIETARY ITEM	PER ASME Y14.5M-1994	SIZE A3	SYSTEM NX	DWG NO. J-R4-20-40-401
EXCEPT FOR USES EXPRESSLY GRANTED IN WRITING, INFORMATION DISCLOSED HEREON IS CONFIDENTIAL AND ALL RIGHTS, PATENT AND OTHERWISE, ARE RESERVED BY SOUTHCO, INC.		DRAWN BY VK	DATE 17FEB2016	SCALE 1:1 SHEET 1 OF 1

