

REVISION HISTORY			
REV	DATE	BY	DESCRIPTION
B	15FEB2017	SX/BX	PRN: P2017-0393

THE PERFORMANCE GUIDELINES SHOWN ON THIS PAGE ARE SUPPLIED AS A GENERAL GUIDE ONLY. AS CONDITIONS VARY WITH EACH APPLICATION AND METHOD OF INSTALLATION, STRENGTH DATA IS GIVEN FOR FAILURE OF THE PRODUCT OR FOR SUFFICIENT DEFORMATION TO MAKE THE PRODUCT INOPERABLE. NO SAFETY FACTOR HAS BEEN APPLIED. IT IS RECOMMENDED THAT HE USER REQUEST A PRODUCT SAMPLE FOR TESTING TO DETERMINE THE SUITABILITY OF THE PRODUCT FOR HE PURPOSE INTENDED AND USER'S PARTICULAR APPLICATION.

	AVERAGE TENSILE ULTIMATE STRENGTH ON THE PAWL	AVERAGE ULTIMATE PADDLE STRENGTH	MAXIMUM INSTALLATION TORQUE	CYCLE LIFE AT 20N BUMPER LOAD FROM DOOR	AVERAGE ACTUATION FORCE TO OPEN AT 20N BUMPER LOAD FROM DOOR
R4-81	1500N	4100N	4.5N-m	40000	33-35N

1. ULTIMATE STRENGTH AND INSTALLATION TORQUE TESTS WERE PERFORMED WITH PART NUMBER R4-81-221-50.
2. CONSULT SOUTHCO FOR OTHER TECHNICAL DETAILS.

DIRECTION OF ULTIMATE PADDLE STRENGTH

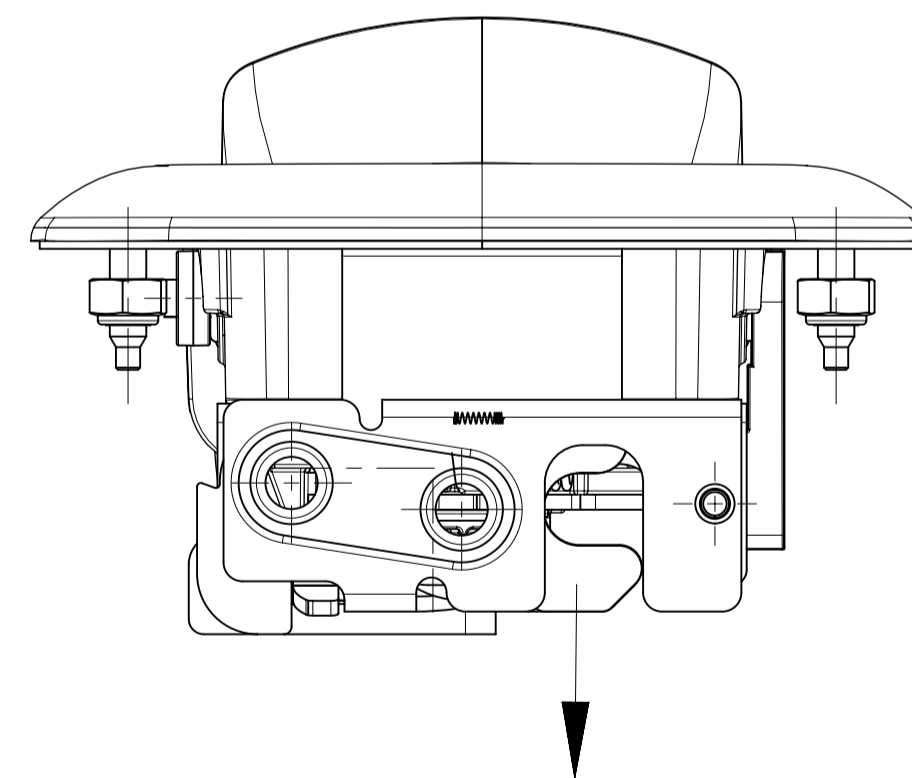
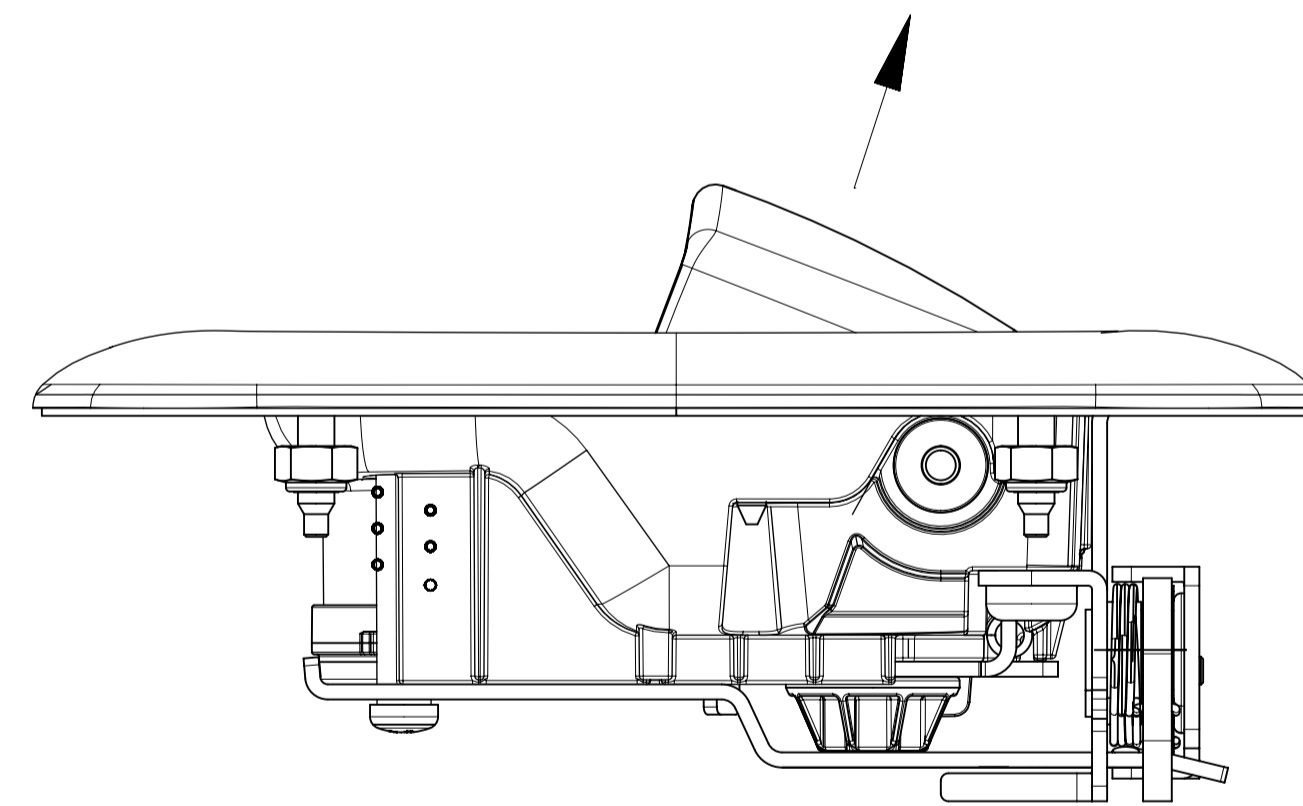

DIRECTION OF TENSILE ULTIMATE STRENGTH

NOTE:
SOUTHCO LATCH BE TESTED IN SIMULATED FIXTURE
MUST BE FULLY TESTED IN ACTUAL APPLICATION SYSTEM

TEST REPORT: trR4-28526

THIRD ANGLE PROJECTION				southco [®] CONNECT • CREATE • INNOVATE	
MILLIMETERS [IN]				DESCRIPTION ROTARY PADDLE LATCH	
SURFACE AREA XXXXXmm ²		TOLERANCES UNLESS OTHERWISE NOTED		SIZE SYSTEM A1 NX	
VOLUME XXXXXmm ³		UP TO 0.5 ±0.05 OVER 0.5 UP TO 6 ±0.1 OVER 6 UP TO 30 ±0.2 OVER 30 ±0.3 ANGLES ±1°		DWG. NO. TD-R4-81	
PROPRIETARY ITEM EXCEPT FOR USES EXPRESSLY GRANTED HEREON IS CONFIDENTIAL AND ALL RIGHTS, PATENT AND OTHERWISE, ARE RESERVED BY SOUTHCO, INC.		PER ASME Y14.5M-1994		DRAWN BY SX/BX DATE 07APR2015 SCALE 1:1 SHEET 1 OF 1	