

## GENERAL PERFORMANCE GUIDELINES

The information shown on this page was determined under one set of test conditions. Since conditions vary with each application, it is supplied as a general guide only. No safety factor has been applied. We recommend testing the product under actual application conditions to determine its suitability for the intended use.

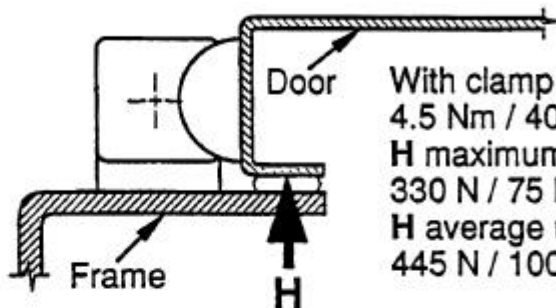

With clamp screw tightened to 4.5 Nm / 40 in-lbs. of torque;  
**H** maximum working load is 330 N / 75 lbs.  
**H** average ultimate load is 445 N / 100 lbs.

### PART NUMBERS

96-10-570  
 96-10-572  
 96-50-570

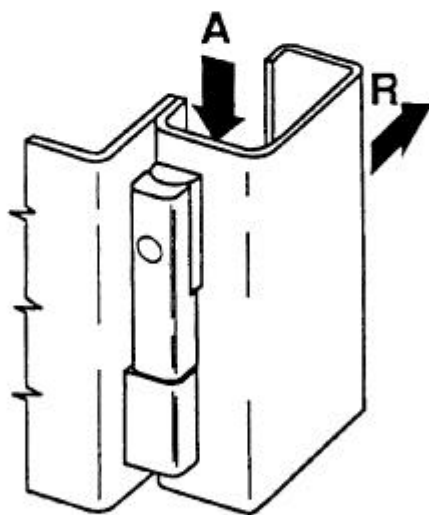

### A

Suggested WORKING FORCE<sup>①</sup>: 2220 N / 500 LBS  
 Average ULTIMATE FORCE<sup>②</sup>: 14230 N / 3200 LBS

### R

Suggested WORKING FORCE<sup>①</sup>: 1000 N / 225 LBS  
 Average ULTIMATE FORCE<sup>②</sup>: 1550 N / 350 LBS

**TORQUE LIMITS** - Maximum recommended tightening torque on mounting screws = 4.5 Nm / 40 inch-pounds.  
 Recommended clamp screw tightening torque = 4.5 Nm / 40 inch-pounds.

- ① WORKING FORCE is the maximum force that the product will withstand without affecting the operation or appearance of the product.
- ② Average ULTIMATE FORCE causes failure of the product or sufficient deformation to make the product inoperable.

DRAWING NUMBER  
TD-96-03-J

SCALE  
—

CHKD

DRAWN  
GJC

DATE  
4-91

SOUTHCO  
COMPRESS ADJUSTABLE

**southco**

DRAWING NUMBER

TD-96-03-J