

REVISION HISTORY			
REV	DATE	BY	DESCRIPTION
B	08MAY2020	MBT/DMS	PRN: P2020-0856

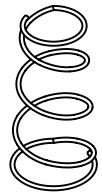
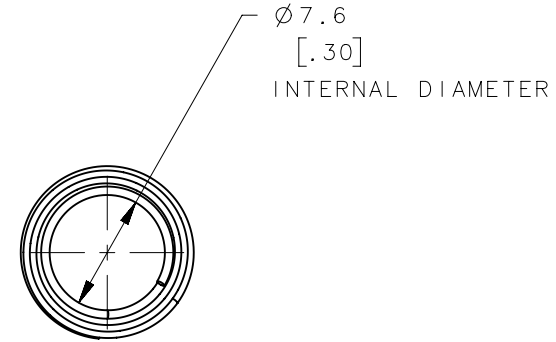
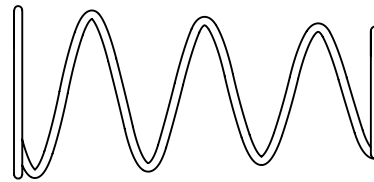
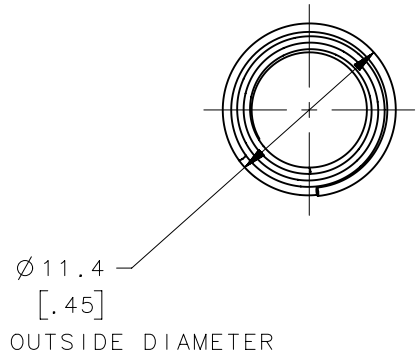

SCALE 1:1

D4-EHF5-3-550	SPRING	$\varnothing 0.56$ [.02] 302 CRES	CLEAN	14.0 [.55]
D4-EHF5-3-650	SPRING	$\varnothing 0.56$ [.02] 302 CRES	CLEAN	16.5 [.65]
D4-EHF5-3-800	SPRING	$\varnothing 0.56$ [.02] 302 CRES	CLEAN	20.3 [.80]
D4-EHF5-3-850	SPRING	$\varnothing 0.56$ [.02] 302 CRES	CLEAN	21.6 [.85]
D4-EHF5-3-900	SPRING	$\varnothing 0.56$ [.02] 302 CRES	CLEAN	22.9 [.90]
D4-EHF5-3-950	SPRING	$\varnothing 0.56$ [.02] 302 CRES	CLEAN	24.1 [.95]
PART NUMBER	TYPE OF COMPONENT	MATERIAL	FINISH	FREE LENGTH

NOTES: UNLESS OTHERWISE SPECIFIED

1. SPRING TO BE WOUND LEFT HAND
2. ENDS TO HAVE 270° MINIMUM FLAT SEATS
3. ADD 'QA' AT THE END OF THE PART NUMBER FOR TRACEABILITY.

THIRD ANGLE PROJECTION		southco [®] CONNECT • CREATE • INNOVATE		
MILLIMETERS [IN]				
TOLERANCES UNLESS OTHERWISE NOTED		DESCRIPTION SPRING, EHF5		
ALL DIMENSIONS WITHOUT TOLERANCES ARE FOR REFERENCE ONLY.		SIZE A4	SYSTEM NX	DWG NO. J-D4-EHF5-3
PROPRIETARY ITEM <small>EXCEPT FOR USES EXPRESSLY GRANTED IN WRITING, INFORMATION DISCLOSED HEREON IS CONFIDENTIAL AND ALL RIGHTS, PATENT AND OTHERWISE, ARE RESERVED BY SOUTHCO, INC.</small>		DRAWN BY YGC	DATE 19 MAY 2010	SCALE 2:1
PER ASME Y14.5M-1994		SHEET 1 OF 1		