

REVISION HISTORY			
REV	DATE	BY	DESCRIPTION
C	08DEC2012	MWC/YGC	PRN: P2012-1730

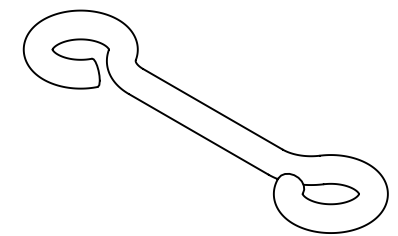

SCALE 3:1

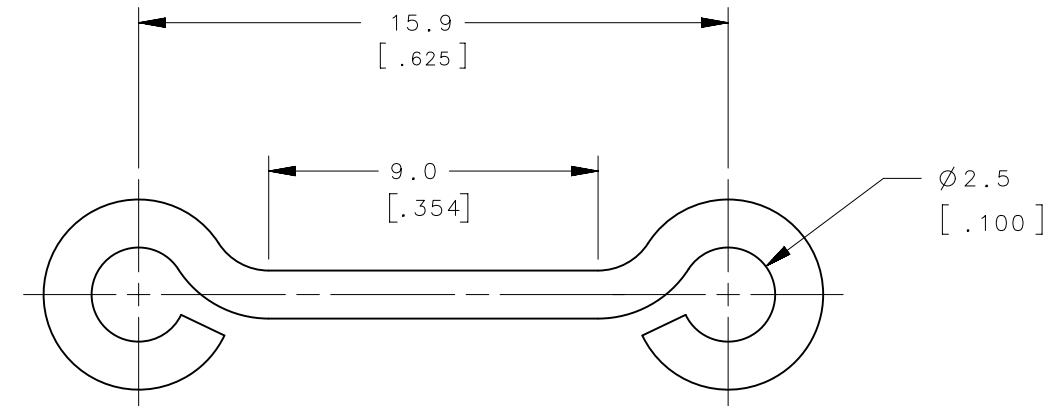

Ø 2.5 DRILL AND
[.1] COUNTERSINK
Ø 4.8 X 110°
[.19]

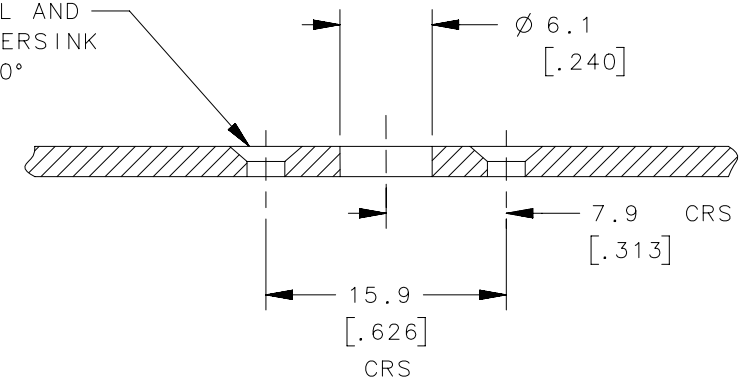

1 DRILL HOLES AND
COUNTERSINK RIVET HOLES

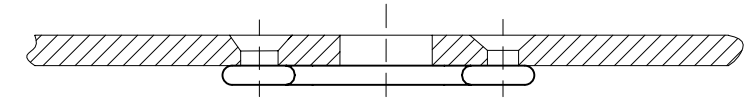
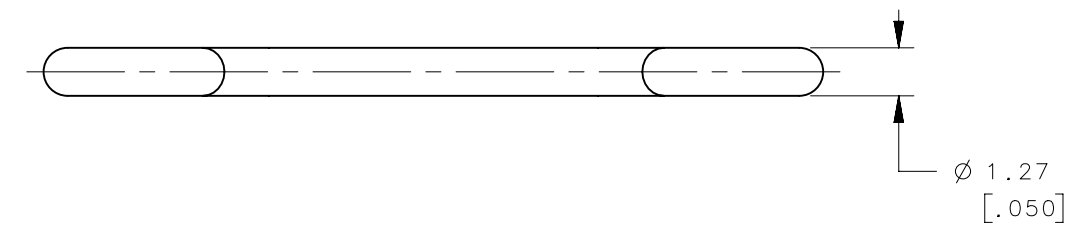

2 RIVET WIRE TO SUPPORT

D5-PB35 FLAT MOUNTED SPRING INSTALLATION

D5-PB35QA	CARBON STEEL	CADMIUM PLATE
D5-PB35SS	STAINLESS STEEL	PASSIVATED
D5-PB35	CARBON STEEL	ZINC PLATE
PART NUMBER	MATERIAL	FINISH

THIRD ANGLE PROJECTION	MILLIMETERS [IN]	 CONNECT • CREATE • INNOVATE		
TOLERANCES UNLESS OTHERWISE NOTED		SIZE A3	SYSTEM NX	DWG NO. J-D5-PB35
ALL DIMENSIONS WITHOUT TOLERANCES ARE FOR REFERENCE ONLY.		PER ASME Y14.5M-1994	DRAWN BY MJW	DATE 05OCT2005
<small>PROPRIETARY ITEM EXCEPT FOR USES EXPRESSLY GRANTED IN WRITING, INFORMATION DISCLOSED HEREON IS CONFIDENTIAL AND ALL RIGHTS, PATENT AND OTHERWISE, ARE RESERVED BY SOUTHCO, INC.</small>		SCALE 5:1	SHEET 1 OF 1	