

REVISION HISTORY			
REV	DATE	BY	DESCRIPTION
0	06JUN2022	GJL/MBT	PRN: P2022-1037

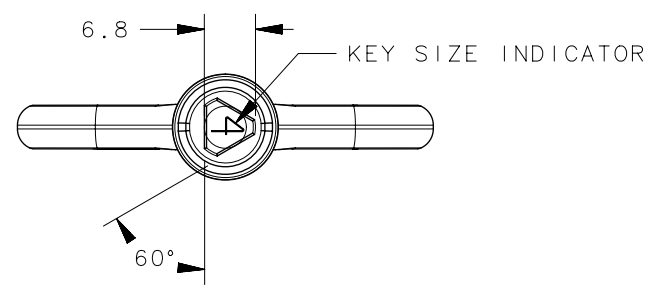

E3-3-1  
E3-3-2  
7mm TRIANGLE TOOL

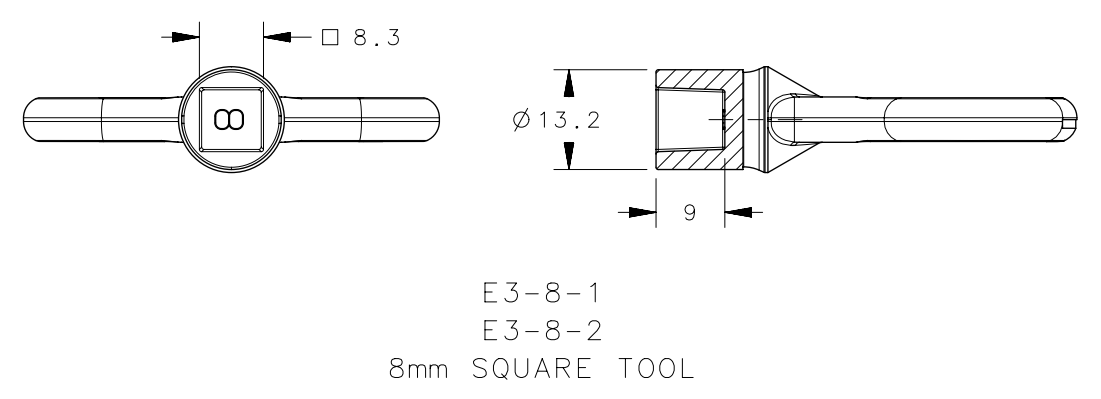
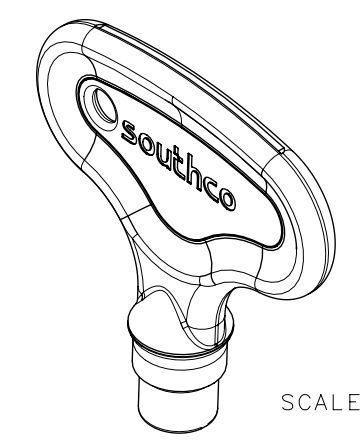
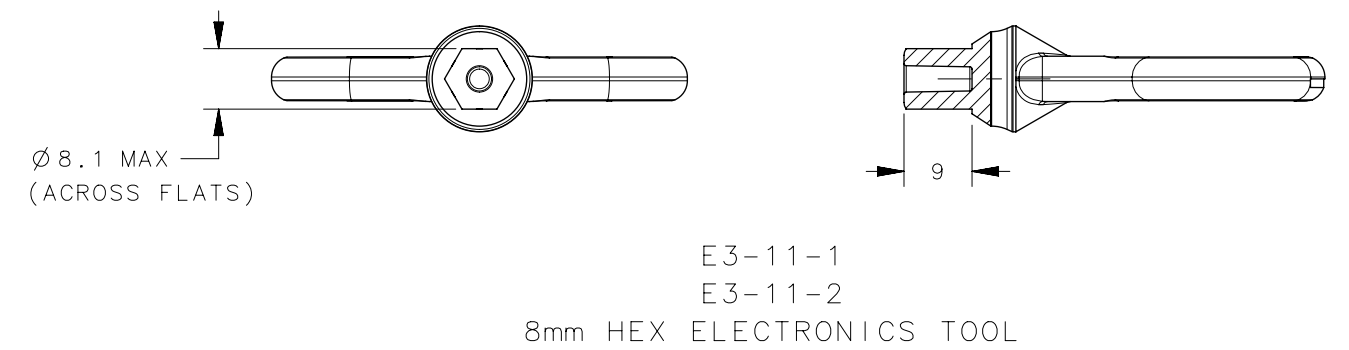
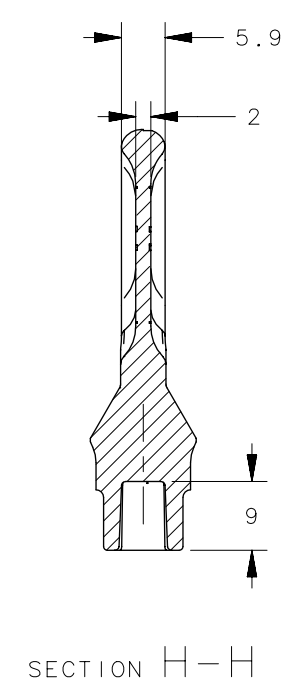
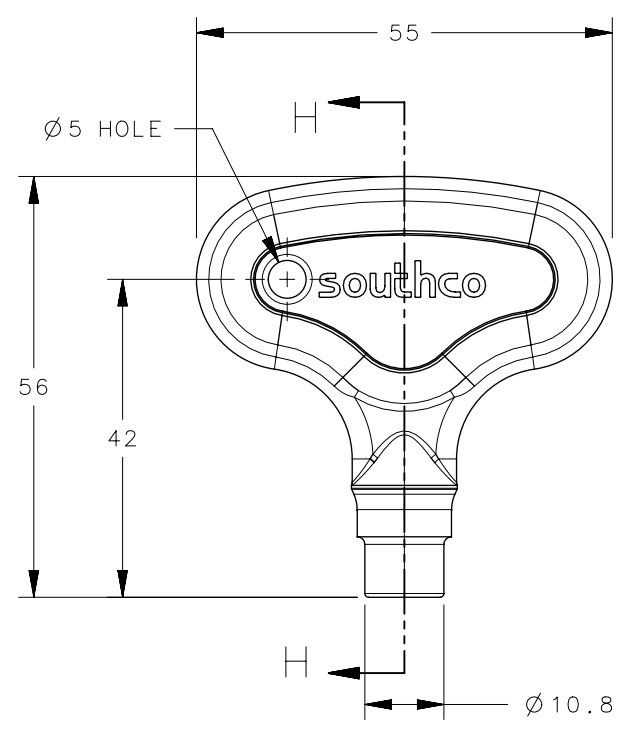
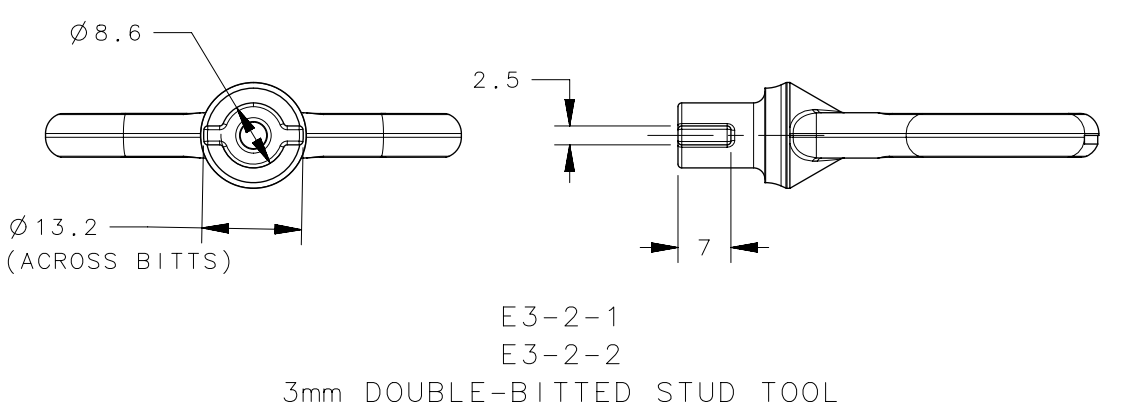

E3-2-1  
E3-2-2  
3mm DOUBLE-BITTED STUD TOOL

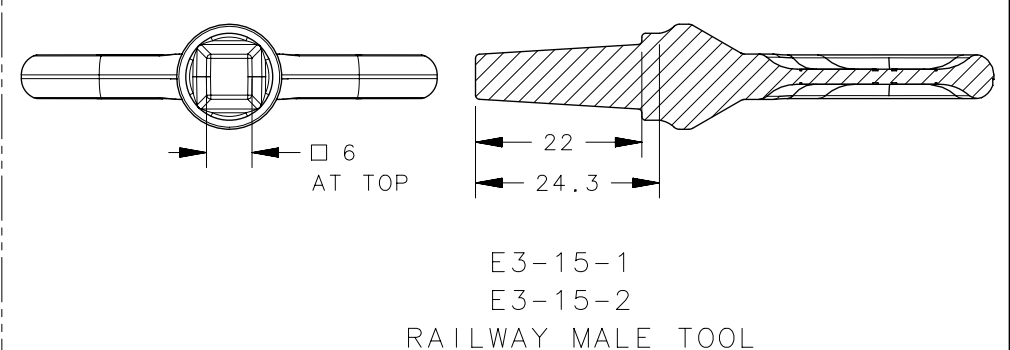

E3-15-1  
E3-15-2  
RAILWAY MALE TOOL

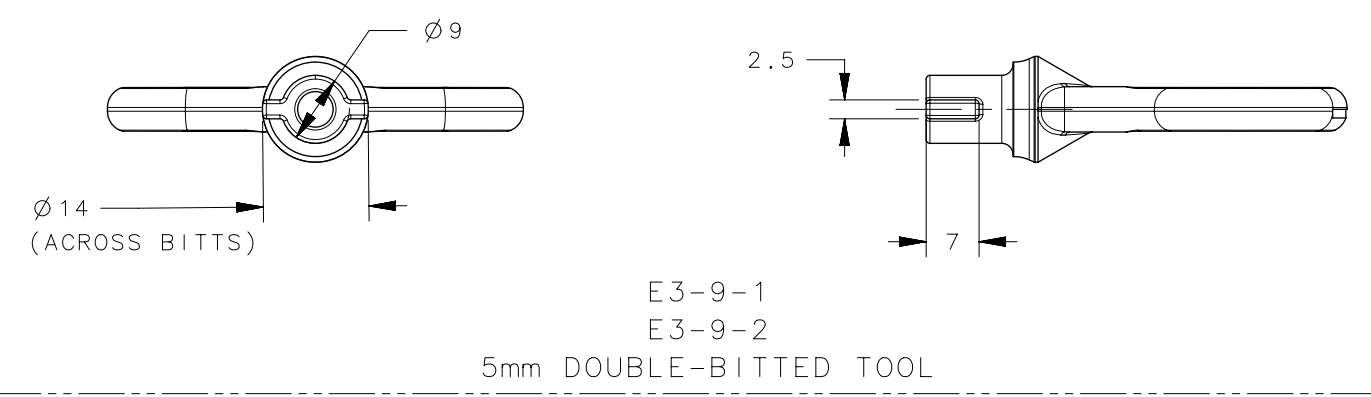

E3-9-1  
E3-9-2  
5mm DOUBLE-BITTED TOOL

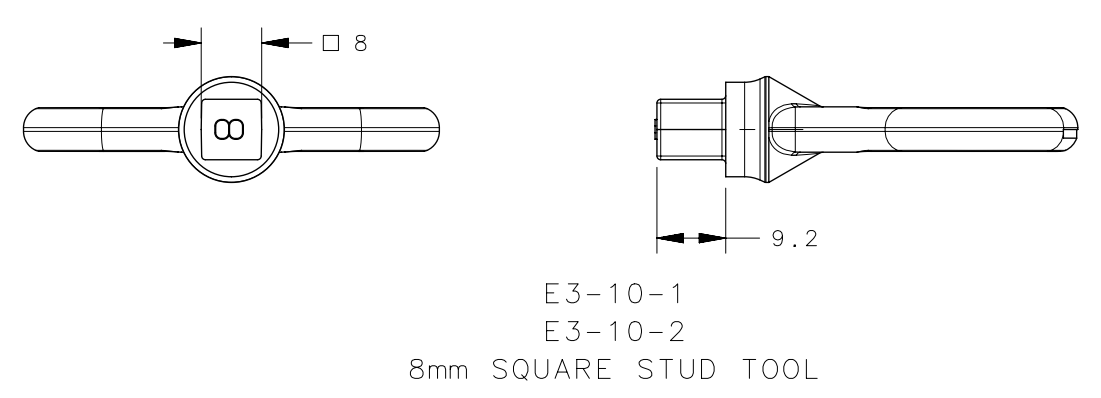

E3-10-1  
E3-10-2  
8mm SQUARE STUD TOOL

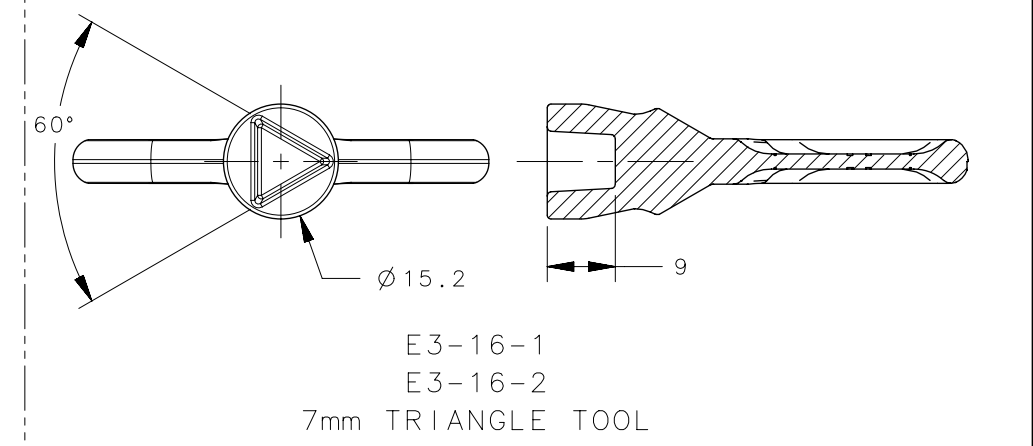

E3-16-1  
E3-16-2  
7mm TRIANGLE TOOL

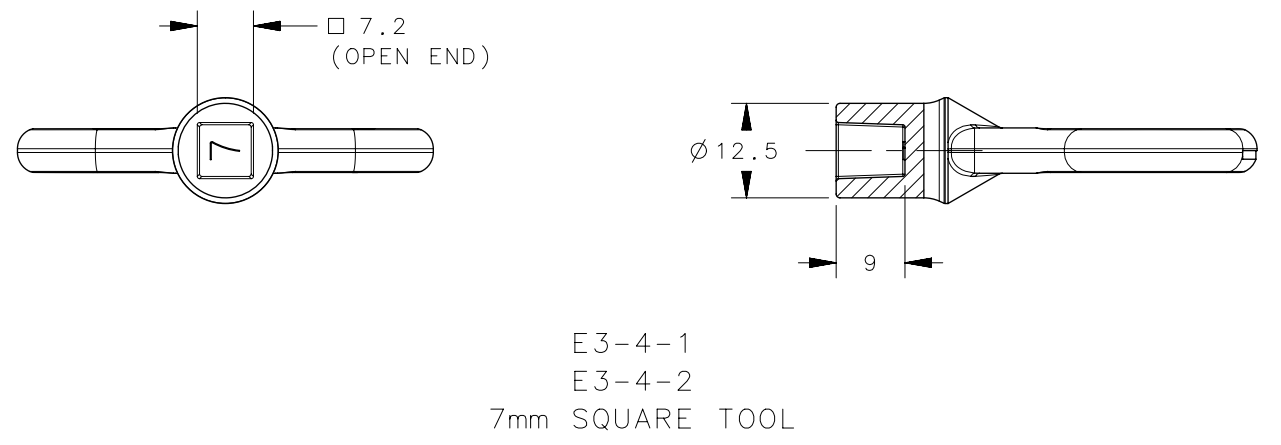

E3-4-1  
E3-4-2  
7mm SQUARE TOOL

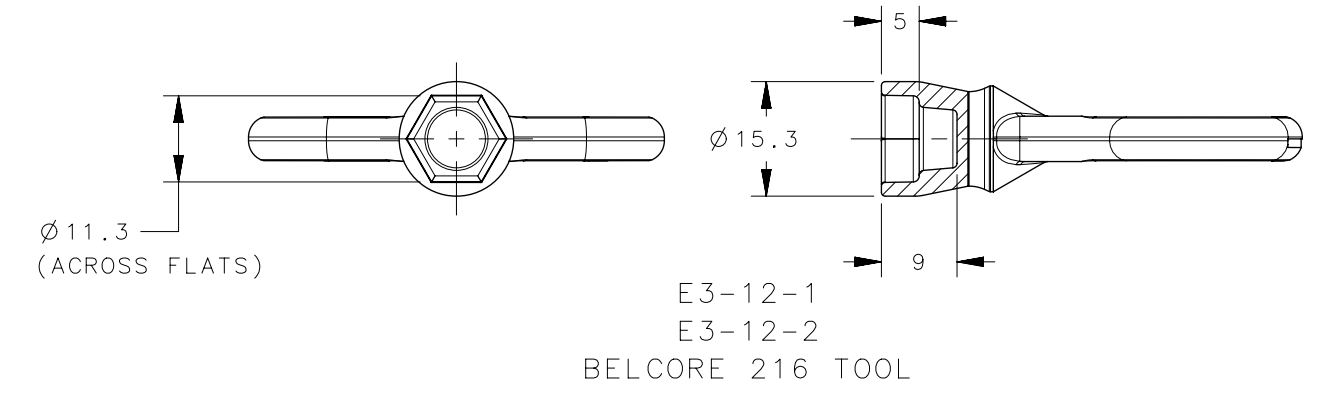

E3-12-1  
E3-12-2  
BELCORE 216 TOOL

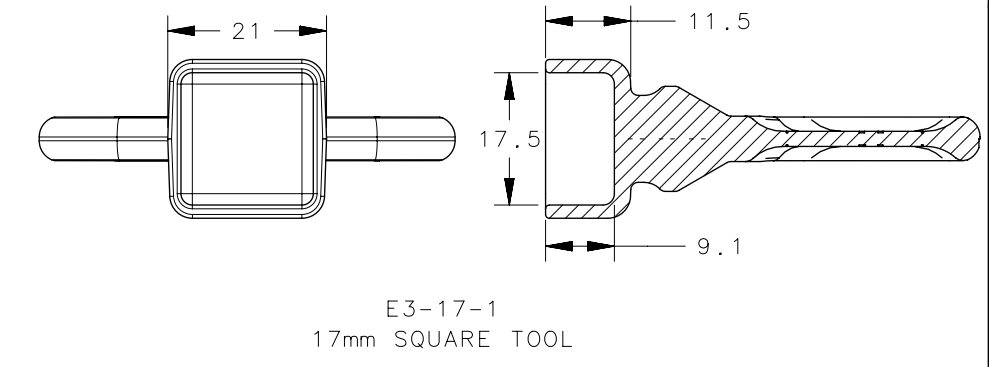

E3-17-1  
17mm SQUARE TOOL

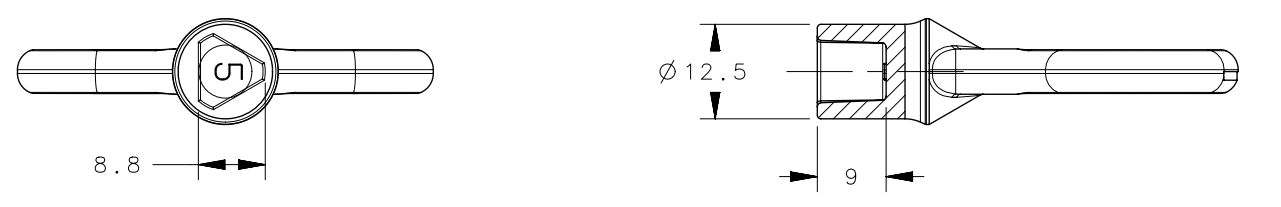

E3-7-1  
E3-7-2  
M5 (8mm) TRIANGLE TOOL

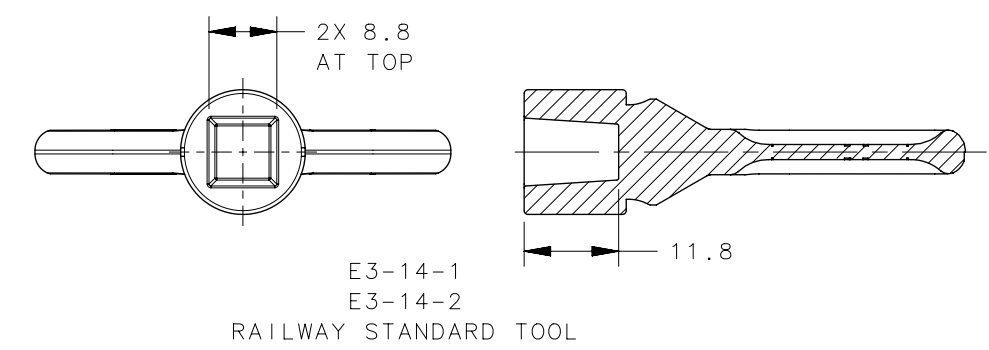

E3-14-1  
E3-14-2  
RAILWAY STANDARD TOOL

NOTES:  
 A. ALL KEYS USE THE SAME WING WITH DIFFERENT TOOL ENDS.  
 B. DIGITS \*XX\* IN THE PART No. IDENTIFY KEY BIT STYLE (EX. XX=8 (8mm SQUARE)).  
 C. FOR NYLON KEYS SEE J-E3-3-1.

E3-XX-2	KEY	DIE CAST ZINC	NATURAL WITH CHEMICAL PROTECTIVE FILM
E3-XX-1	KEY	DIE CAST ZINC	BRIGHT NICKEL PLATE
PART NUMBER	TYPE OF COMPONENT	MATERIAL	FINISH
	THIRD ANGLE PROJECTION		
	MILLIMETERS [IN]		
SURFACE AREA	TOLERANCES UNLESS OTHERWISE NOTED		
VOLUME	ALL DIMENSIONS WITHOUT TOLERANCES ARE FOR REFERENCE ONLY.		
PROPRIETARY ITEM	EXCEPT FOR USES EXPRESSLY GRANTED IN WRITING, INFORMATION DISCLOSED HEREON IS CONFIDENTIAL AND ALL RIGHTS, PATENT AND OTHERWISE, ARE RESERVED BY SOUTHCO, INC.		
	PER ASME Y14.5M-1994	DRAWN BY	DATE
		ALC	13JUN2000
		SCALE	SHEET
		1:1	1 OF 1



DESCRIPTION  
**E3/E5 OPERATING TOOLS, AS FINISHED**

SIZE SYSTEM  
 A2 NX DWG NO.  
**J-E3-2-1**