

General Performance Guidelines

The information shown on this page was determined under one set of test conditions and is supplied as a general guide only for failure of the product or for sufficient deformation to make the product inoperable. No safety factor has been applied. It is recommended that the user test the product for his particular application.

TENSILE
(LEAVES IN LINE)

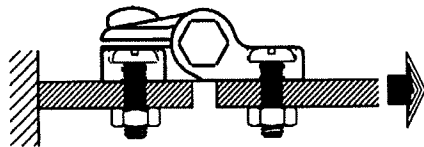

TENSILE
(LEAVES PERPENDICULAR)

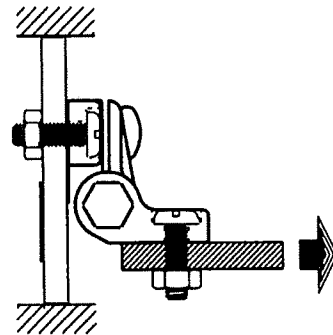

SHEAR

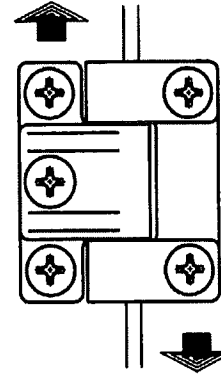

TORQUE

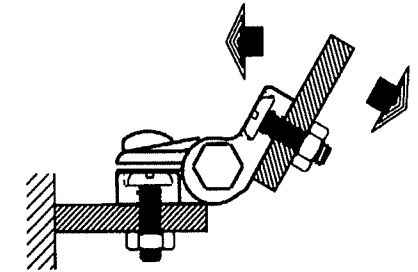

PART NUMBER	WORKING TENSILE LOAD		ULTIMATE TENSILE LOAD		WORKING SHEAR	ULTIMATE SHEAR	MAXIMUM PREVAILING TORQUE	MINIMUM CYCLE LIFE ①
	IN LINE	PERPENDICULAR	IN LINE	PERPENDICULAR				
	N / lb	N / lb	N / lb	N / lb	N / lb	N / lb	N-cm/in-lbs	
E6-10-301-XX	1330 / 300	330 / 75	1780 / 400	600 / 135	660 / 150	890 / 200	80 / 7	20,000
E6-10-501-XX	2220 / 500	1220 / 275	3110 / 700	2220 / 500	1330 / 300	2000 / 450	400 / 35	20,000

① ONE CYCLE = CLOSED POSITION TO OPEN POSITION AT 90° PLUS RETURN TO INITIAL CLOSED POSITION.

REF: E6-13, 15, 16, 17

FORMATA 3/88

PROPRIETARY ITEM - EXCEPT FOR USES EXPRESSLY GRANTED IN WRITING INFORMATION DISCLOSED HEREON IS CONFIDENTIAL AND ALL RIGHTS PATENT AND OTHERWISE ARE RESERVED BY SOUTHCO, INC.

REV. A 6-6-86 GCL PRN: E6-39
REV. B 12-21-92 BTW ADDED WORKING TENSILE AND WORKING SHEAR, ADDED 300 SERIES DATA, REDRAWN ON CAD.
REV. C 17AUG95 MMM REVISED PER PRN: E6-89.
REV. D 05SEP95 MAC REVISED PER PRN: E6-89A

DRAWING NUMBER

TD-E6-1-J