

REV B	DATE 09APR2002	DRAWN/CHKD GDM	DESCRIPTION UPDATE FORMAT	FLUSH SIMPLICITY™ LATCH	DATE 19NOV93	DRAWN BDS	CHKD ACZ	SCALE N.T.S.	DRAWING NUMBER TD-M1-2-J

THIRD ANGLE PROJECTION

A
PAPER
SIZE

GENERAL PERFORMANCE GUIDELINES

The information shown on this page was determined under one set of test conditions. Since conditions vary with each application, it is supplied as a general guide only. No safety factor has been applied. We recommend testing the product under actual application conditions to determine its suitability for the intended use.

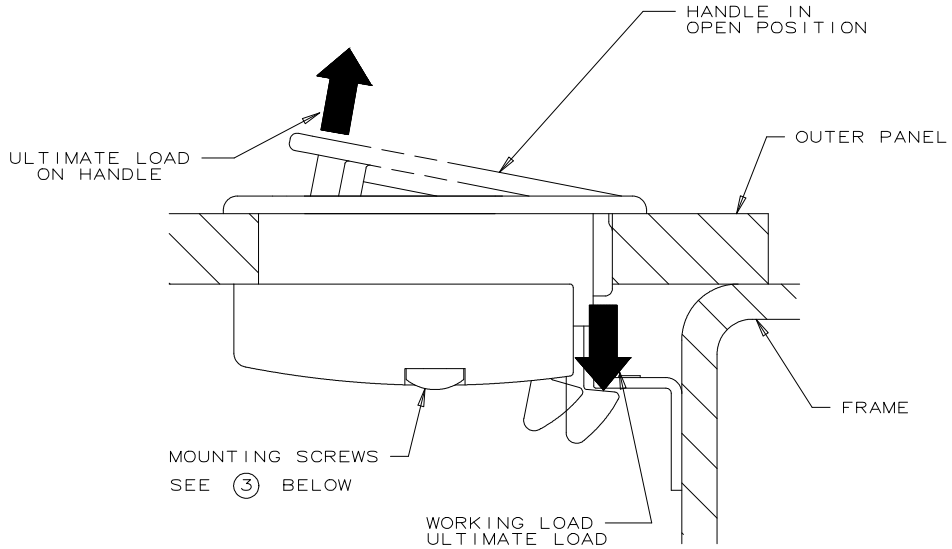

PART NUMBER	MAX RECOMMENDED WORKING LOAD ①	ULTIMATE LOAD ON LATCH ②	ULTIMATE LOAD ON HANDLE ②	MAX RECOMMENDED TIGHTENING TORQUE ON MOUNTING SCREWS ③
M1 - 8001 802 803	135 N (30 LBS)	170 N (38 LBS)	200 N (45 LBS)	50-80Ncm(5-7IN-LBS)

CYCLE LIFE @ 20°C (68°F) = 100,000+ CYCLES

- ① WORKING LOAD is the maximum force that the product will withstand without affecting the operation or appearance of the product.
- ② Average ULTIMATE LOAD causes failure of the product or sufficient deformation to make the product inoperable.
- ③ CAUTION: Do not over-tighten screws.

southco®

REF: M1-05

PROPRIETARY ITEM - EXCEPT FOR USES EXPRESSLY GRANTED IN WRITING INFORMATION DISCLOSED HEREON IS CONFIDENTIAL AND ALL RIGHTS PATENT AND OTHERWISE ARE RESERVED BY SOUTHCO, INC.